



TUFF COUNTRY

EZ-RIDE SUSPENSION

INSTALLATION MANUAL

5.5" SUSPENSION SYSTEM
1998-99 DODGE DURANGO
(Front End)

SJ101199

WARNING: TUFF COUNTRY EZ-RIDE SUSPENSION HIGHLY RECOMMENDS THAT A CERTIFIED MECHANIC PERFORMS THIS INSTALLATION.

PART NO. DD5I / Dodge Durango
PARTS LIST:

Qty.	Description	Part No.
1	Rear Cross Member	DD5I-01
1	Front Cross Member	DD5I-02
2	Upper Control Arm Drop Brackets	DD5I-03
2	Lower Control Arm Drop Brackets-Rear	DD5I-04
2	Lower Control Arm Drop Brackets-Front	DD5I-05
1	Emergency Brake Cable Extensions (Durango Only)	DD5I-06
1	Steering Stabilizer Bracket	DD5I-07
1	Differential Drop Bracket / Rear - Pass. Side	DD5I-11
1	Differential Drop Bracket / Front - Pass. Side	DD5I-12
1	Differential Drop Bracket / Rear - Driver Side	DD5I-13
1	Differential Drop Bracket / Middle -Driver Side	DD5I-14
1	Differential Drop Bracket / Front Driver Side	DD5I-15
1	Differential Kicker Support / Driver Side	DD5I-16
1	Differential Kicker Support / Pass. Side	DD5I-17
1	Steering Assist	DD5I-18
2	Upper Control Arm Rear support Bracket	DD5I-19
1	Lateral Compression Arm Mount Plate	DD5I-20
1	Steering Center Link	DD5I-21
2	Lateral Compression Arms	DD5I-22
4	Brake Line Relocating Brackets	DD5I-23
1	Upper Cross Member - Rear	DD5I-24
2	Torsion Bar Drop Plates - Cast Iron	DD5I-25
2	Upper Control Arm Front Support Bracket	DD5I-27
2	Sway Bar Drop Brackets / Rear (Durango)	F405
4	Lateral Compression Mounts	C6I-112
1	Steering Stabilizer	TC87350
1	Steering Stabilizer Dust Boot	TC-0100
4	U-bolt - 9/16 x 3 1/2 x 10 1/2 - round	5U-283R
1	U-bolt Nut and Washer Pack	916NW
1	Hardware Box	DD5I-NB123
1	Poly Bushing Pack	D3IPL
1	Sleeve Pack	DD5ISL
4	Bump Stops	BS1
2	Sert fittings	SERT
1	Differential fill plug	DD5I-28
2	6 Degree Axle Shims	DS6-01
1	3/8" Centering Bolts and Nuts	CB38
1	Instruction Sheet	DD5I-INST

Warning

Do not install a body lift with this suspension system. If a body lift is installed, warranty will be void.

For all parts, please refer to Parts Description Pages, at the end of Installation Manual

WARNING

If you desire to return vehicle to stock height, save all stock components

Congratulations on your selection to purchase a Tuff Country Suspension System. We at Tuff Country are proud to offer a high quality product at the industries most competitive pricing. Thank you for your confidence in us, and our product.

***Important Notes:** Please read before beginning installation. OEM Manual should be used as a reference.

Important Notice: Due to the rotation of the front differential on this installation, the differential cover plate must be modified. See installation step #10 for details. If this modification is not performed properly, severe damage will occur to the rear tail shaft bearing.

TUFF COUNTRY SUSPENSION highly recommends a qualified and or certified mechanic to perform this installation.

Check off parts list to be sure all parts are on hand. If any part is missing, you may call Tuff Country at: (800) 288-2190.

Read and understand all sections of instruction manual.

Use lockite on all bolts associated with this installation.

Recommended Tire Size: 33" x 12.5" x 15" or 285/75-16
Recommended Wheel Size 16 x 8 Medium offset

Front End Installation

Please following instructions carefully:

1. Safely lift vehicle by placing jack stands under frame rails.
2. Remove wheels and tires. Next remove differential skid plate.
3. Measure exposed threads on torsion bar adjustment and record for later use.

Record measurement here. _____

4. Remove the torsion bar adjuster bolt making sure to keep hands clear. **Warning: This is a free floating torsion bar and carries extreme tension.** Once adjuster bolt has been removed, remove the stock torsion bar adjuster arm and set aside. This part will not be re-installed. Repeat procedure on opposite side.

5. Mark both torsion bars before removal so that they can be re-installed back in the same position as removed. i.e. front and rear of torsion bar and driver side and passenger side of torsion bar. Tap torsion bars forward until torsion bar arms can be removed.

6. Slide torsion bars out of lower control arm and set aside for later re-installation.

7. Remove front shocks. Next remove brake line bracket from front brackets on driver side and passenger side making sure not to kink or bend.

8. Remove front sway bar and set aside for later re-installation.

9. Using a tie rod separating tool, remove tie rod ends from steering knuckle. Next, remove tie rod assembly from stock center link for later re-installation. Remove steering linkage from idler arm and pitman arm and save hardware, **Note: Be careful not to tear the boots on the idler and pitman arm.** Save steering linkage and tie rod ends. New steering linkage will be used, stock tie rod end will be re-installed at a later step.

10. Drain front differential and remove differential cover. **Note: Make certain that the differential is completely drained.** Next, locate the stock differential cover fill plug. Measure from the center of fill plug directly up 1 3/4" and scribe a mark. Now drill (1) 3/4" hole. Make sure to clean and clear any metal shavings or burrs. Set newly modified differential cover plate aside for later re-installation. **Warning: Due to the rotation of the front differential during this installation, modification of differential cover is required. This modification will ensure that the rear of the tail shaft bearing receives enough fluid. If this modification is not performed properly, severe damage will occur to rear tail shaft bearings.**

(See Illustration #1)

11. Remove the stock upper rear cross member located directly behind front differential **save hardware** and cross member. A new upper rear cross member will be install at a later step.

12. Next remove the stock bolts from the lower control arms on both the driver side and passenger side (both front and rear of control arms) and let lower control arms hang. **Note: New hardware will be used.**

(See Illustration #2)

13. **Front Lower Control Arm Brackets:** Install new front lower control arm drop bracket on driver side to stock front

lower control arm mounting point using (1) 7/16" x 4 1/2" bolt, (2) 7/16" washers and (1) 7/16" lock nut. Bolt through stock hole and new bracket, **let hang.** Install new front lower control arm drop bracket on passenger side to stock lower control arm mounting point using (1) 7/16" x 4 1/2" bolt, (2) 7/16" washers and (1) 7/16" lock nut. Bolt through stock hole and new bracket, **let hang.**

(See Illustration #3)

14. **Rear Lower Control Arm Brackets:** First locate (4) BS1 - Bump stop, (4) 3/8" lock nuts and (4) 3/8" flat washers. On driver side rear lower control arm drop bracket install (1) bump stop in the upper inner hole secure using 3/8" hardware. On the lower inner part of the bracket there are two holes, install (1) bump stop in the forward hole secure using 3/8" hardware. Install new rear lower control arm drop bracket on driver side to stock rear lower control arm mounting point using (1) 1/2" x 4 1/2" bolt, (2) 1/2" washers, (1) 1/2" lock nut. Bolt through stock hole and new bracket, **let hang.** **On passenger side rear lower control arm drop bracket install (1) bump stop in the upper inner hole secure using 3/8" hardware. On the lower inner part of the bracket there are two holes, install (1) bump stop in the forward hole secure using 3/8" hardware.** Install new rear lower control arm drop bracket on passenger side to stock lower control arm mounting point using (1) 1/2" x 4 1/2" bolt, (2) 1/2" washers, (1) 1/2" lock nut. Bolt through stock hole and new bracket, **let hang.**

(See Illustration #4)

15. **Front Cross Member:** Install new front cross member to stock front cross member. Secure using previously removed lower sway bar bolts. Do not fully tighten. **Note: Make certain that the threaded spud of new front cross member is toward the front of the vehicle.**

(See Illustration #5)

16. Install the new drivers side front lower control arm drop brackets to the front cross member. **Note: The front of the new driver side front lower control arm drop bracket will be installed on the outside of the new front cross member. The back of the new driver side front lower control arm drop bracket will be installed on the inside of the new front cross member.** Secure using (4) 7/16" x 1 1/2" bolt, (8) 7/16" washers and (4) 7/16" lock nuts. **Repeat procedure on passenger side. Do not fully tighten at this point.**

(See Illustration #6)

17. Go back to all hardware associated with the new front cross member, the new front lower control arm drop brackets and the new rear lower control arm drop brackets and torque to specs.

18. On the driver side install the stock lower control arm into the new front lower control arm drop bracket. Secure using (1) 7/16" x 4 1/2" bolt, (1) 7/16" lock nut and (2) 7/16" flat washers. Continuing on the driver side install the

stock lower control arm into the new rear lower control arm drop bracket. Secure using (1) 1/2" x 4 1/2" bolt, (1) 1/2" lock nut and (2) 1/2" flat washers. **Repeat procedure on passenger side. Note: Do not fully tighten.**

(See Illustration #7 Front / Illustration #8 Rear)

19. Steering Stabilizer Bracket: Locate the passenger side stock sway bar mounting stud, tap out and remove stud. Install the new steering stabilizer bracket into the upper hole where stud bolt was located. Secure using (1) 1/2" x 1 1/2" bolt, (1) 1/2" lock nut and (2) 1/2" flat washers. **(Make sure the new steering stabilizer is in the vertical position)** Use the bottom hole in new stabilizer bracket as a guide and drill a 7/16" hole through the frame. Secure bottom hole by using (1) 7/16" x 1 1/2" bolt, (1) 7/16" lock nut and (2) 7/16" flat washers.

(See Illustration # 31)

20. Securely support front differential by using a hydraulic jack. Next remove all stock differential mounting bolts from the frame and the differential **Note: There are a total of (5) differential mounting points.** Next ease off on jack stand and lower differential approximately 5" to 5 1/2" to make room for new differential lowering brackets. **Note: Make sure all wires and hoses have plenty of clearance.**

21. Front Passenger Side Differential Drop Bracket: Locate the front passenger side differential drop bracket and passenger side differential kicker support bracket. Starting on the front of differential on the passenger side, insert (2) 1/2" x 3/4" crush sleeves between stock passenger side differential mount. Install new front differential drop bracket on the inside of stock mounts rearward position, with bend at the top and angling back. Secure using (2) 1/2" x 3" bolts, (2) 1/2" lock nuts and (4) 1/2" flat washers. **Do not fully tighten.** (See Illustration # 9) Now attach differential to the front side of new differential brackets **outward hole only** using (1) 1/2" x 3" bolt, (1) 1/2" lock nut and (2) 1/2" flat washers. **Do not fully tighten.** Now install the kicker support bracket to the stock passenger side lower control arm bracket, lower hole. **(Hole already provided).** Secure using (1) 7/16" x 1 1/2" bolt, (1) 7/16" lock nut and (2) 7/16" flat washers. Now attach the opposite end of kicker support bracket to the inward hole of the passenger side front differential bracket's lower hole. Secure using (1) 1/2" x 3" bolt, (1) 1/2" lock nut and (2) washers.

(See Illustration #10)

22. Front Driver Side Differential Drop Bracket: Locate the front driver side differential drop bracket and the driver side differential kicker support bracket. Starting on the front of differential on the driver side, insert (2) 1/2" x 3/4" crush sleeves between stock driver side differential mount. Install new front differential drop bracket on the inside of stock mounts forward position, with the bend at the top angling back. Secure using (2) 1/2" x 3" bolts, (2) 1/2" lock nuts and (4) 1/2" washers. (See Illustration # 11) Now attach differential to the front of the new differential brackets **inside hole only** using (1) 1/2" x 3" bolt, (1) 1/2" lock nut and

(2) 1/2" flat washers. **Note: Do not fully tighten.** Now install the kicker support bracket to the stock lower control arm bracket, upper hole. **(Hole already provided).** Secure using

(1) 7/16" x 1 1/2" bolt, (1) 7/16" lock nut and (2) 7/16" flat washers. Now attach the opposite end of kicker support bracket to the outward hole of the front differential bracket's lower hole. Secure using (1) 1/2" x 3" bolt, (1) 1/2" lock nut and (2) 1/2" flat washers. **Do not fully tighten**

(See Illustration # 12)

23. Passenger Side Rearward Differential Drop Bracket:

Locate the passenger side rearward differential drop bracket. Install the new bracket to the stock differential mounting point. **Note: Make sure the bend in new bracket is facing toward the passenger side of vehicle.** Secure using (2) 1/2" x 1 1/2" bolts, (2) 1/2" lock nuts and (4) 1/2" washers. Next secure the differential to the new passenger side rear drop bracket using the two stock bolts. **Note: Make sure to use locktite.**

(See Illustration # 13)

24. Driver Side Middle Differential Drop Bracket:

Locate the driver side middle differential drop bracket. Install the new bracket to the stock mounting point. **Note: Make sure that the bend in new bracket is placed in a backward "Z" position as you are viewing from the rear of differential.** Secure using (1) 1/2" x 1 1/2" bolt, (1) 1/2" lock nut and (2) 1/2" flat washers. Next secure differential to the new driver side middle differential drop bracket using stock bolt. **Note: Make sure to use locktite.**

(See Illustration # 14)

25. Rear Driver Side Differential Drop Bracket:

Locate the rear driver side differential drop bracket. Install the new bracket to the inside of the stock mounting point. Secure using (1) 1/2" x 1 1/2" bolt, (1) 1/2" lock nut and (2) 1/2" flat washers. **Note: Make sure to mount the new bracket on the inside portion of stock mounting bracket.** Next secure front differential to the new bracket using stock bolt. **Note: Make sure to use locktite.**

(See Illustration # 15)

26. Go back to all hardware associated with the new differential drop brackets and torque to specs.

27. Locate the new upper cross member (tubular) and install in the same location as previously removed stock cross member from step #11. Secure using stock hardware. **Note: Some vehicle come stock without upper crossmember, if this is the case the new upper rear cross member is not needed to be installed.**

(See Illustration # 16)

28. Rear Lateral Compression Arm Mounts: Locate (2) rear lateral compression mounts and lateral compression arm plate. Install the new lateral compression arm plate to the stock transmission cross member located approximately in the middle of chassis straight back from rear lower cross member. First secure the new plate in place by using (1) 1/2" x 1 1/2" bolt, (1) 1/2" lock nut and (2) 1/2" flat washers, in the center hole of new plate. On the driver side of the new lateral compression arm plate install (1) lateral compression mount to the outer hole on mounting plate. Secure using (1) 1/2" x 1 1/2" bolt, (1) 1/2" lock nut and (2) 1/2" flat washers. On the passenger side of the new lateral compression arm plate install (1) lateral compression mount to the outer hole on mounting plate. Secure using (1) 1/2" x 1 1/2" bolt, (1) 1/2" lock nut and (2) 1/2" flat washers. **Torque bolts to spec.**

(See Illustration # 17)

29. Lower Rear Cross Member and Lateral Compression Arm Mounts: Locate the new lower rear cross member and the new front lateral compression arm mounts. Install the new lower rear cross member to the driver side of the new lower rear control arm drop brackets. Secure using (2) 1/2" x 1 1/2" bolts, (2) 1/2" lock nuts and (4) 1/2" flat washers to the front holes on the new cross member and the new rear driver side lower control arm. **Note: Do not fully tighten** Install the new lower rear cross member to the passenger side of the new lower rear control arm drop brackets. Secure using (2) 1/2" x 1 1/2" bolts, (2) 1/2" lock nuts and (4) 1/2" flat washers to the front holes on new cross member and the new rear passenger side lower control arm. **Note: Do not fully tighten** On the driver side new rear lower control arm drop bracket install the rear outer hole to the new rear cross member. Secure using (1) 1/2" x 1 1/2" bolt, (1) 1/2" lock nut and (2) 1/2" washers. **Note: Do not fully tighten** On the passenger side new rear lower control arm drop bracket install the rear outer hole to the new rear cross member. Secure using (1) 1/2" x 1 1/2" bolt, (1) 1/2" lock nut and (2) 1/2" washers. **Note: Do not fully tighten** Now install (1) lateral compression mount on the driver side inner bolt hole of the new cross member and secure using (1) 1/2" x 1 1/2" bolt, (1) 1/2" lock nut and (2) 1/2" flat washers. **Note: Do not fully tighten** Next, install (1) lateral compression mount to the passenger side inner bolt hole of the new cross member and secure using (1) 1/2" x 1 1/2" bolt, (1) lock nut and (2) 1/2" flat washers. **Tighten all bolts associated with new rear cross member and lateral compression mounts.**

(See Illustration #18 & 19)

30. Lateral Compression Arms: Locate the new lateral compression arms, poly bushings and steel sleeves. Now install poly bushings part # MO2050 in each end of lateral compression arms. (2 per side, 4 per arm.) Insert (1) 9/16" x 2 1/8" crush sleeves into each end of the new lateral compression arms. **Note: Make sure to use a lithium or moly base grease on new bushings and sleeves.** On the driver side install the new lateral

compression arm by inserting into the newly installed rear lateral compression arm mount. Secure using (1) 1/2" x 3 1/2" bolt, (1) 1/2" lock nut and (2) 1/2" washers. **Note: Do not fully tighten.** On the passenger side install the new lateral compression arm by inserting into the newly installed rear lateral compression arm mount. Secure using (1) 1/2" x 3 1/2" bolt, (1) 1/2" lock nut and (2) 1/2" washers. **Note: Do not fully tighten.** Next, install lateral compression arms to the newly installed front mounts, secure using (2) 1/2" x 3 1/2" bolts, (2) 1/2" lock nuts and (4) 1/2" flat washers. **Tighten all hardware associated with the newly install lateral compression arms.**

(See Illustration # 39)

31. Install modified front differential cover using stock bolts and OEM approved sealant. **Note: Replacement gasket may be needed.** Torque to factory specifications (refer to OEM manual for proper torque settings.) Now, using previously drilled upper filler hole in differential cover, fill with OEM approved differential fluid. Fill fluid to bottom of new hole. Next, install new filler plug provided into new hole. **Note: It is very important that the differential is completely filled to the bottom of new hole. This will ensure that adequate fluid level is achieved.**

32. Supporting lower control arms. Remove upper brake line mounting bolts. Remove upper control arm alignment bolts and remove upper control arms from stock pivot brackets. Safely support brackets so that CV joints do not extend and let hang. **Note: Save the stock alignment bolts for later re-installation.**

33. On both sides of the frame near upper control arm mounts, unbolt the stock rubber compression bump stops from their steel frame mount brackets, and discard. With a suitable cutting tool carefully trim the steel frame mount bump stop brackets flush with frame on driver side and passenger side allowing new upper control arm drop brackets to mount **flush to frame.** **Note: Do not cut or grind into the frame. CAUTION: UNDERCOATING IS FLAMMABLE.** Grind and clean all cutting slag from the trimming performed in this installation step. Paint and undercoat any exposed metal.

(See Illustration # 20)

34. Driver Side Upper Control Arm Drop Bracket: Locate the new driver side upper control arm drop bracket. Install the new driver side upper control arm drop brackets to stock frame rail bracket front hole. Secure using (1) 1/2" x 1 1/2" bolt, (1) 1/2" lock nut and (2) 1/2" washers. **Do not fully tighten at this point.** Locate new front brakeline extension bracket. Now install the rear hole of the new driver side upper control arm drop bracket to stock frame rail bracket rear hole. Also at this time install new brakeline extension bracket. Secure using (1) 1/2" x 1 1/2" bolt, (1) 1/2" lock nut and (2) 1/2" flat washer. **Note: Slope of new bracket must go to the rear of vehicle.**

(See Illustration # 21 & 30)

- 35. Passenger Side Upper Control Arm Drop Bracket:** Locate the new passenger side upper control arm drop bracket. Install the new driver side upper control arm drop brackets to stock frame rail bracket rear hole. Secure using (1) 1/2" x 1 1/2" bolt, (1) 1/2" lock nut and (2) 1/2" washers. Do not fully tighten at this point. Locate new front brakeline extension bracket. Now install the front hole of the new passenger side upper control arm drop bracket to stock frame rail bracket front hole. Also at this time install new brakeline extension bracket. Secure using (1) 1/2" x 1 1/2" bolt, (1) 1/2" lock nut and (2) 1/2" flat washer. Note: Slope of new bracket must go to the rear of vehicle.
(See Illustration # 22 & 30)
- 36. Upper Control Arm Rear Support Bracket:** Locate the new upper control arm support brackets. Install the support bracket to the inside of driver side upper control arm drop bracket. Secure using (2) 3/8" x 1 1/2" bolts, (2) 3/8" lock nut and (4) 3/8" flat washers. Using holes in support bracket as guide, drill (2) 3/8" holes through upper portion of stock lower rear control arm bracket. Now secure rear support bracket to the back side of the stock upper control arm bracket. Secure using (2) 3/8" x 1 1/2" bolts, (2) 3/8" lock nuts and (4) 3/8" flat washers. Note: Do not fully tighten at this point. Repeat procedure on passenger side. Return back to the driver side of vehicle. Again make sure that the upper control arm bracket is tight against the frame. Now fully tighten the 1/2" bolts on the upper control arm bracket and the 3/8" bolts securing the gusset support bracket to upper control arm bracket. Note: Make sure to tighten the 1/2" bolts first, then the 3/8" bolts next. Repeat procedure on opposite side.
(See Illustration # 23)
- 37. Upper Control Arm Front Support Bracket:** Locate the upper control arm front support brackets. On driver side install front support bracket on the inside of new upper control arm drop bracket. Secure using (1) 7/16" x 1/2" bolt, (1) 7/16" lock nut and (2) 7/16" flat washer. Using bracket as guide drill (2) 5/16" holes into bottom side of frame and secure "L" bracket secure using 3/8 self threading bolts. Repeat on opposite side.
(See Illustration # 24)
- 38. Install stock upper control arms** to the new upper control arm drop bracket alignment slots located on the bottom of new driver side upper control arm drop bracket. Secure using the stock alignment bolts.
(See Illustration # 25)
- 39. Secure stock brake line bracket** to new brake line bracket using (1) 5/16" x 3/4" bolt, (1) 5/16" lock nut and (2) 5/16" flat washer. Repeat procedure on opposite side.
(See Illustration # 30)
- 40. Steering Center Link:** Locate the new steering center link. Install new steering center link to the idler arm and pitman arm. Secure using stock hardware. Note: Make sure that the radius of center link is going toward the rear of vehicle and the short end are mounted to the idler arm and pitman arm. Now install stock tie rod ends to the bottom of new steering center link and outer end of tie rod ends to steering knuckle.
(See Illustration # 32)
- 41. Steering Stabilizer:** Install stabilizer hardware (P19) stud bolt into the hole located on the driver side of new steering center link. Next install steering stabilizer to new bracket and P19 stud bolt. Make sure to install the dust boot cover onto the stabilizer before installation.
(See Illustration # 40)
- 42. Steering Assist:** Locate the steering assist unit, poly bushings and steel crush sleeves. Install new poly bushings, (2 top & 2 bottom) and (2) 9/16" x 2 1/8" crush sleeves (with hole) in new steering assist making sure to grease with moly or lithium base grease. Install steering assist to the middle of center link and secure to front cross member using (2) 9/16" x 3" bolts and washers, making sure to lock tight all bolt threads. Do not fully tighten at this point.
(See Illustration # 26)
- 43. Front Shock Absorbers:** Locate the new front shock absorbers and install the protective rubber dust boots. Use zip tie to secure the boot to the bottom of shock. Install new shock in stock bottom shock mount using stock hardware. Insert the upper shock stem into the new upper control arm drop bracket shock hole and secure using new bushings and hardware.
(See Illustration # 27)
- 44. Check and double check** that all front end components are installed properly. Once all parts are in place, torque all nuts to proper torque settings. (See torque specification sheet).
- 45. Torsion Bar Adjuster Plate:** Install torsion bars into the lower control arms in the same manner as previously removed. Now install the torsion bar adjuster plate onto the rear of the torsion bars. Next install the torsion bar adjuster plate in the stock location and secure using stock hardware.
(See Illustration # 29)
- 46. Position hydraulic floor jack** under rear differential housing and raise rear end until both wheels are off the ground. Place adjustable floor stands on each side of frame rail approximately 3" in front of the spring hanger and lower floor jack so weight of vehicle rests on both floor stands. Both wheels must be off the ground. Leave floor jack in position. Remove both wheels.
- 47. Remove brake cable** and brakeline from axle, next remove both rear shock absorbers and sway bar from rear axle. Raise floor jack until weight of springs are slightly resting on the axle. Remove U-bolts and U-bolt mount plates from both springs.

48. Raise hydraulic floor jack until springs separate from axle pad. Make sure to allow enough space so that the stock springs can safely be removed.

49. Locate the rear spring shackle bolt on the rear of vehicle. Next, remove spring shackle bolt and save for later re-installation. Next, locate and remove the rear spring eye hanger bolt located at the front of the rear leaf spring. Now, remove leaf spring.

50. Locate the new 6 degree tapered shims and new 3/8" center bolts provided. Next place a c-clamp on each side of the new rear leaf springs center bolt, (part no. TCIDD5R). Next remove original center bolt and discard. Install the new 6 degree shim into the new leaf springs, secure using new 3/8" center bolts. Degree shims must be bolted to the top of the leaf spring and the center bolt head must be on the top of leaf spring. **Note: The rear leaf spring is offset from the center bolt to the eye of the leaf spring. Make certain that the tallest end of the degree shims are pointed toward the short end of leaf spring and the smallest end of the degree shims are pointed to the long end of the leaf spring.** Repeat procedure on the other leaf spring.

51. Remove the steel crush sleeves and poly bushings from new leaf springs and lube bushings using a lithium or moly base grease. Next, re-install bushings and steel crush sleeves

52. Install new rear leaf spring, (part no. TCIDD5R) making sure the long portion of the leaf spring is in the rearward position. Secure using stock hardware. **(Do not fully tighten at this time). Note: The rear leaf spring is offset from the center bolt to the eye of the leaf spring. Make certain that the long end goes to the rear of vehicle.**

53. Secure newly installed leaf springs to axle, using new 9/16" x 3 1/2" x 10 1/2" round U-bolts, nuts and washers. Make sure to re-install stock U-bolt plate. **Also be certain that the leaf springs center bolt sits properly into the stock axle pad.** Torque to proper torque settings.

54. Locate rear emergency brake cable extension. From hardware bag # 3 find (4) 5/16" x 1 1/4" bolts, (8) 5/16" flat washers, (4) 5/16" lock nuts and (1) 3/8" x 1 1/4" self threading bolt. On frame right behind rear drivers side tire, remove the three bolts that connect emergency brake cable line to frame. Install new Emergency Brake Cable Extension into stock location with 5/16" hardware. Lower emergency line down and connect stock emergency bracket to the new bracket. Secure using 5/16" hardware. Using stock bracket as a guide, drill 5/16" hole into spring shackle. Secure stock bracket to spring shackle using 3/8" self threading bolt.

(See Illustration # 35)

55. Locate (2) new rear Sway Bar Extension Bracket. From hardware bag # 1 find (4) 7/16" x 1 1/2" bolts, (8) 7/16" flat washers and (4) 7/16" lock nuts. Also locate (1) new brake cable relocating bracket, (1) 5/16" x 1 1/4" bolt, (2) 5/16"

flat washers and (1) 5/16" lock nut. On passenger side place new bracket into stock location and secure bottom of bracket using stock hardware, at this time install new brakeline bracket to forward hole on new sway bar extension bracket. Secure sway bar to new bracket using 7/16" hardware. Connect stock rear brakeline to newly installed brakeline bracket using 5/16" hardware.

(See Illustration # 38)

56. Install new sway bar drop down bracket on driver side the same way it was installed on passenger side. No brake cable relocating bracket is needed on driver side.

57. Locate one brakeline relocating bracket, (1) 5/16" x 1 1/4" bolt, (2) 5/16" flat washers and (1) 5/16" lock nut. On the drivers side inner frame rail above stock spring shackle remove the stock bolt that holds the stock brakeline to frame. Install new brakeline bracket to stock location secure using stock mounting bolt. Now connect stock brakeline bracket to new brakeline relocating bracket and secure using 5/16" hardware.

(See Illustration # 37)

58. Install new rear shocks using stock hardware. Make sure to install dust boot.

59. Re-install tires and wheels and safely lower vehicle to the ground.

60. Now torque the spring shackle bolts and eye hanger bolts to proper torque settings.

61. Install front wheels and tires and lower vehicle to the ground.

62. With the weight on the vehicle, connect the stock front sway bar to the driver side new lower control arm drop brackets using stock hardware. Make sure to install stock sway bar bracket to the back of new lower control arm first, then the bottom hole. **Note: On the new front lower control arms there are two holes, connect the front stock sway bar bracket to the rear hole.** Repeat on opposite side.

(See Illustration # 34)

63. Now connect outer part of stock sway bar to the bottom of stock lower control arm using stock hardware. Repeat on opposite side.

(See Illustration # 33)

Congratulations installation complete. Check and Double Check to make sure that all steps were performed properly. Check torque setting to make sure bolts are torque to proper specs.

Tuff Country recommends that a re-torque is done on all bolts associated with this lift suspension. This should occur 500 miles after the kit has been installed. It is also the customers responsibility to check and re-torque bolts after every 3,000 miles or after every off road use. Neglect of following these steps could cause brackets to come loose and serious damage to the vehicle.

Special Note: After lift kit is installed and alignment has been performed, differential fluid may spill out of the vent hose. If this occurs, check to make sure that differential fluid is not over filled. This will cause fluid to leak out of vent hose.

If any question occur during installation please feel free to call our tech. line. Our business hours are from 8:00 - 6:00 mountain standard time, Monday - Friday. (801) 280-2777

Torque Settings

5/16"	15-18 ft lbs.
3/8"	28-32 ft lbs.
7/16"	30-35 ft lbs.
1/2"	65-85 ft lbs.
9/16"	75-90 ft lbs.
5/8"	85-110 ft lbs

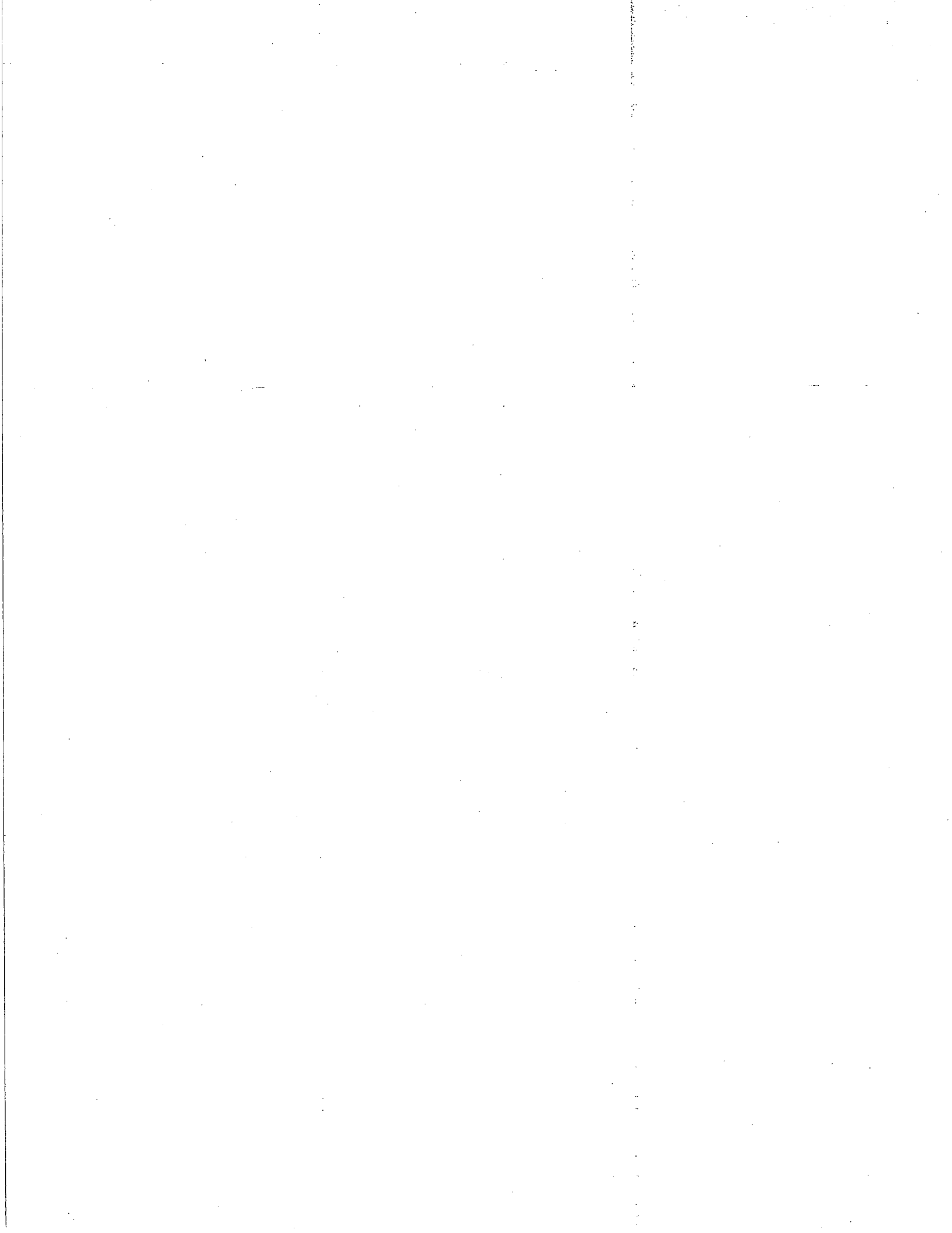

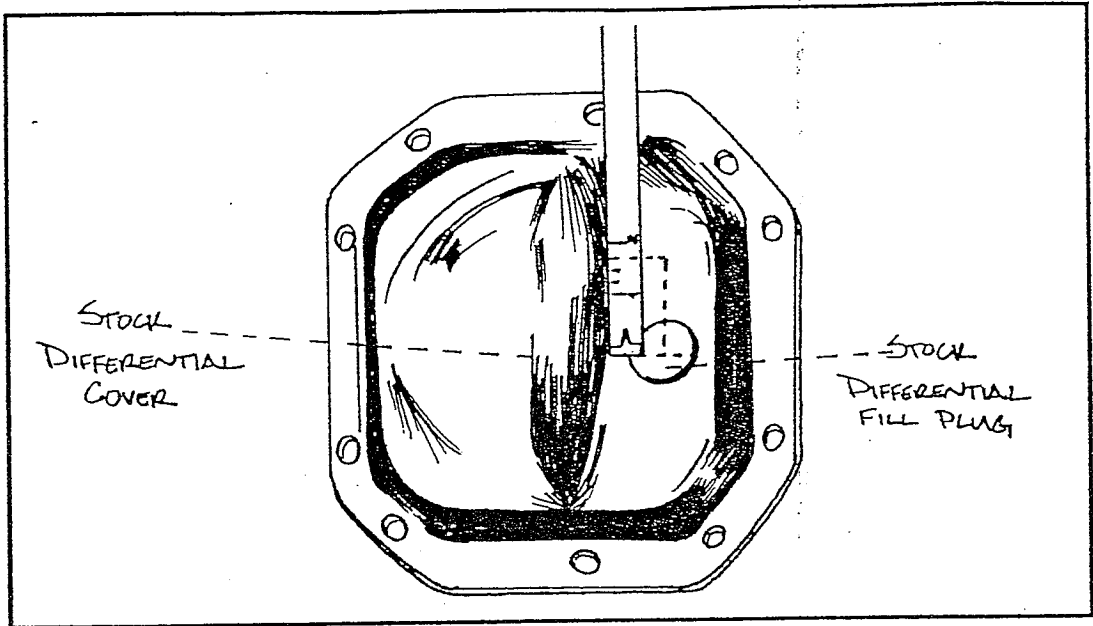

ILLUSTRATION # 1

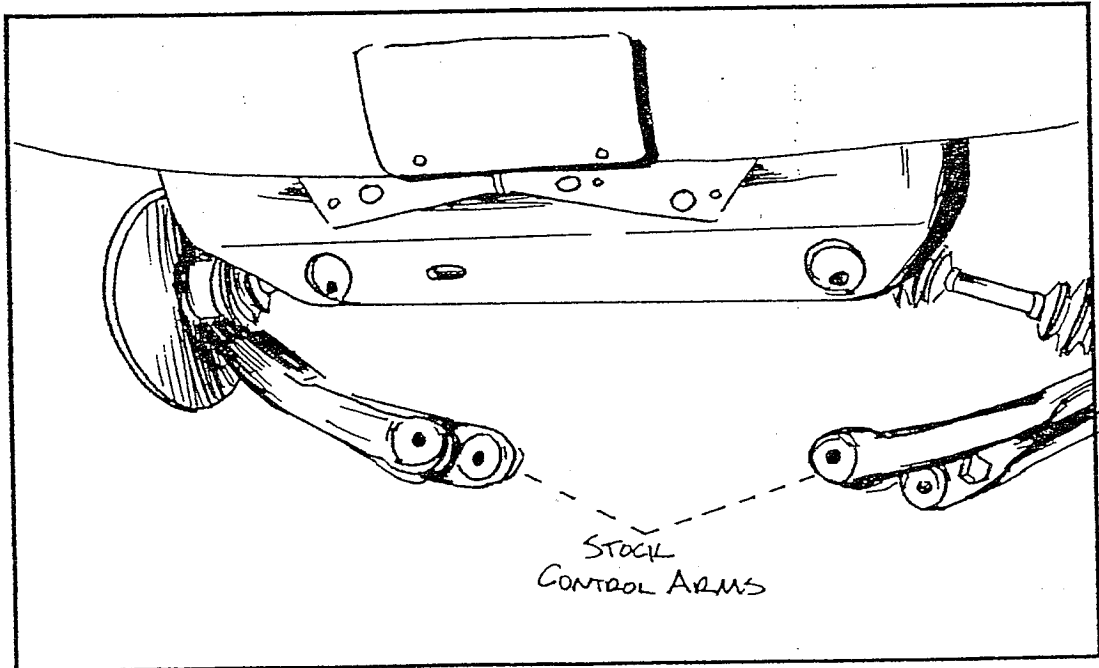

ILLUSTRATION # 2

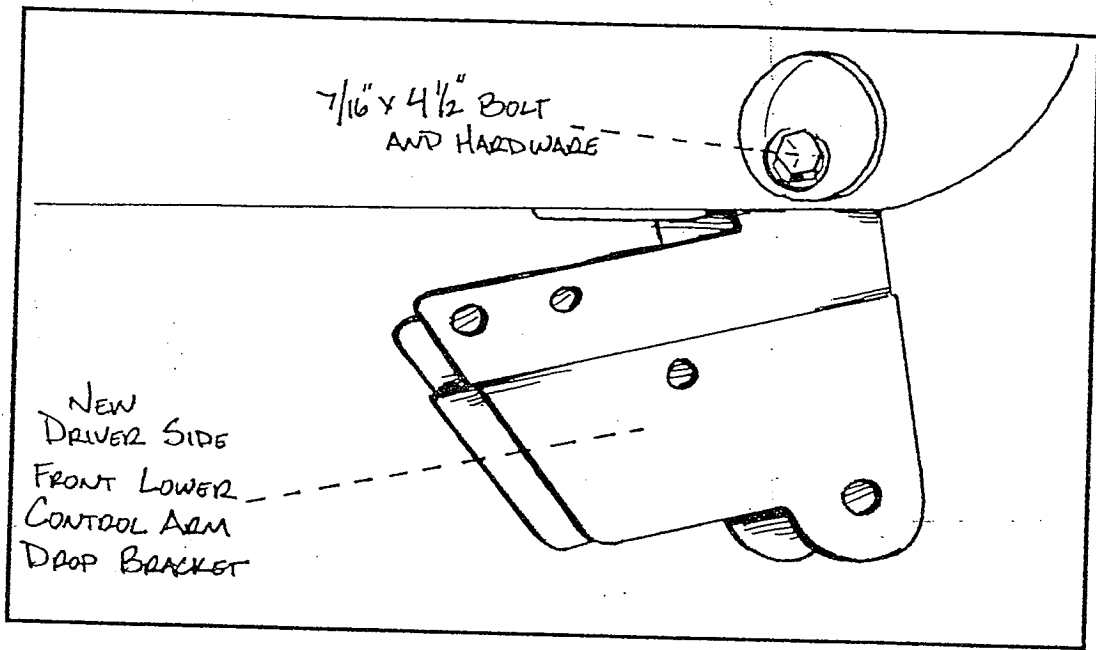

ILLUSTRATION # 3

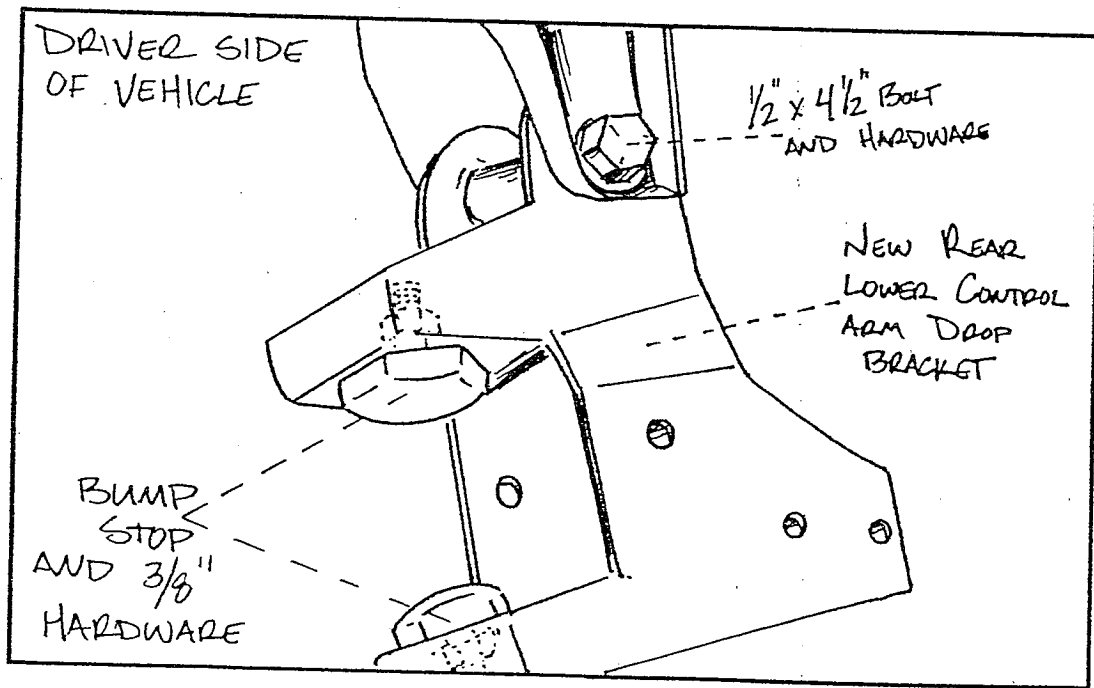

ILLUSTRATION # 4

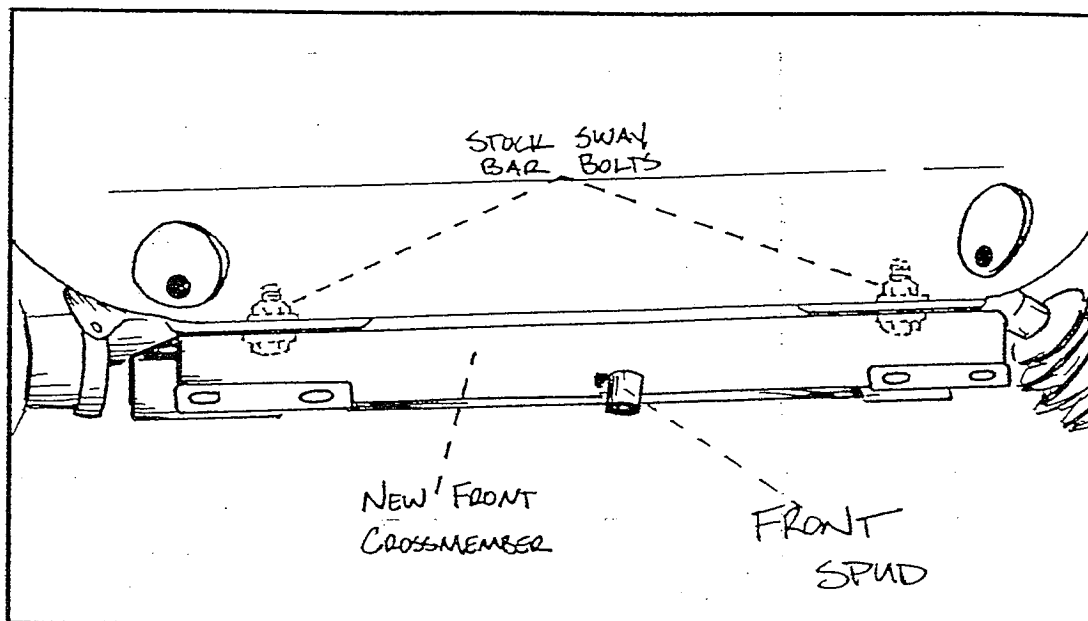

ILLUSTRATION # 5

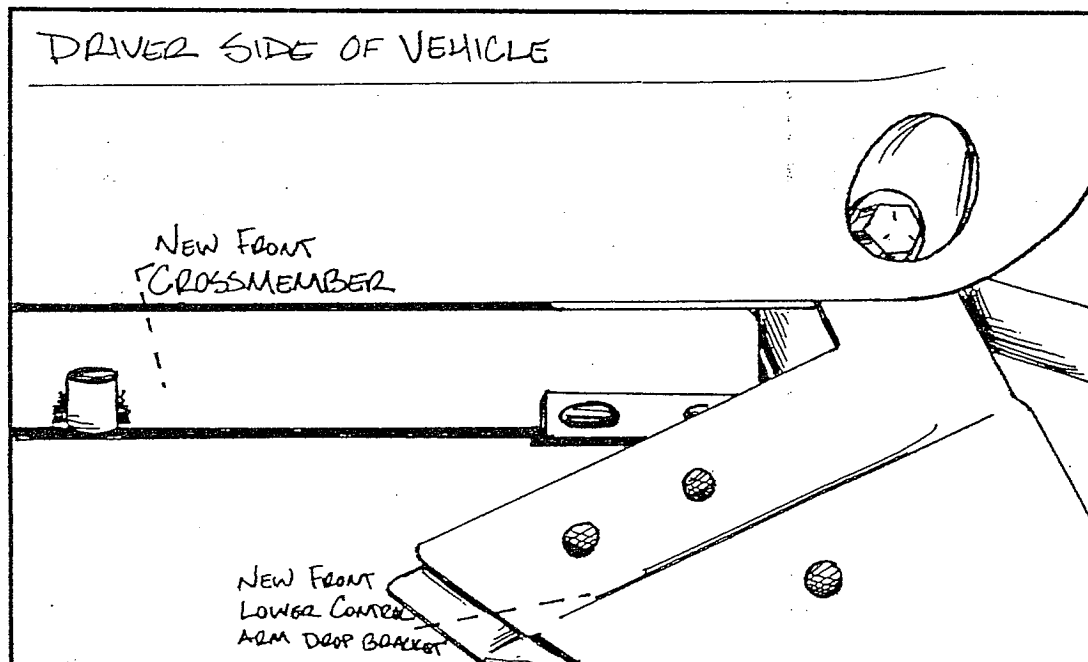

ILLUSTRATION # 6

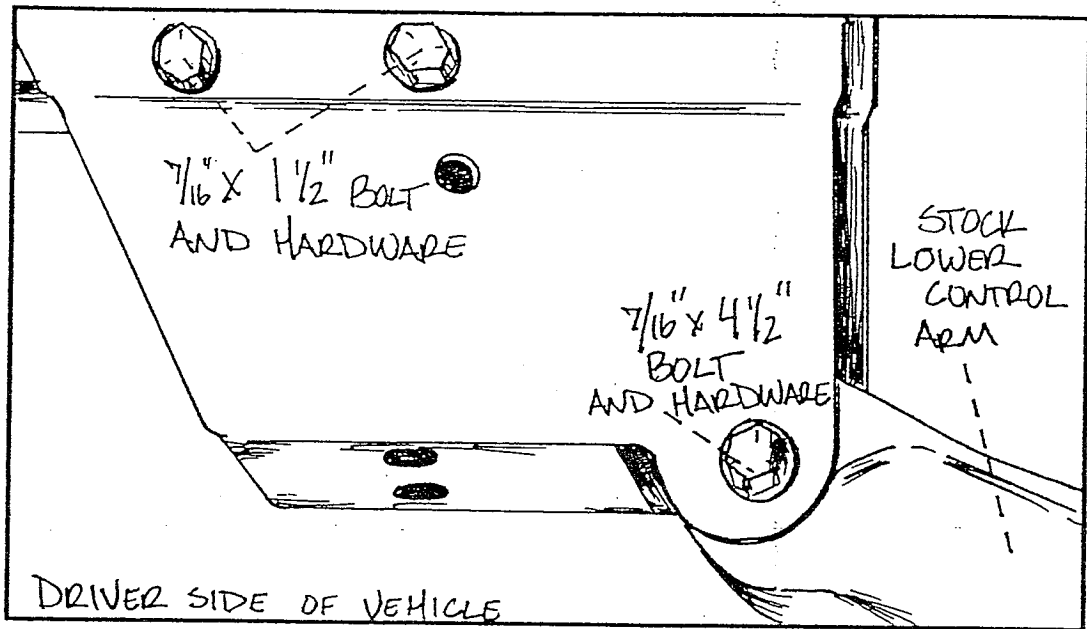

ILLUSTRATION # 7

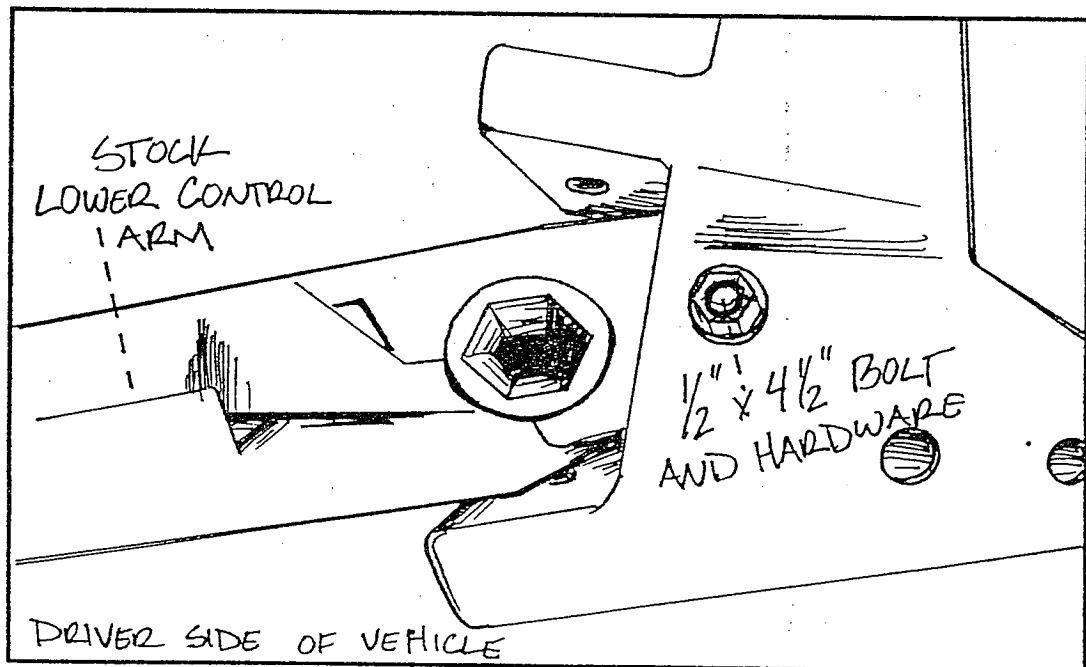

ILLUSTRATION # 8

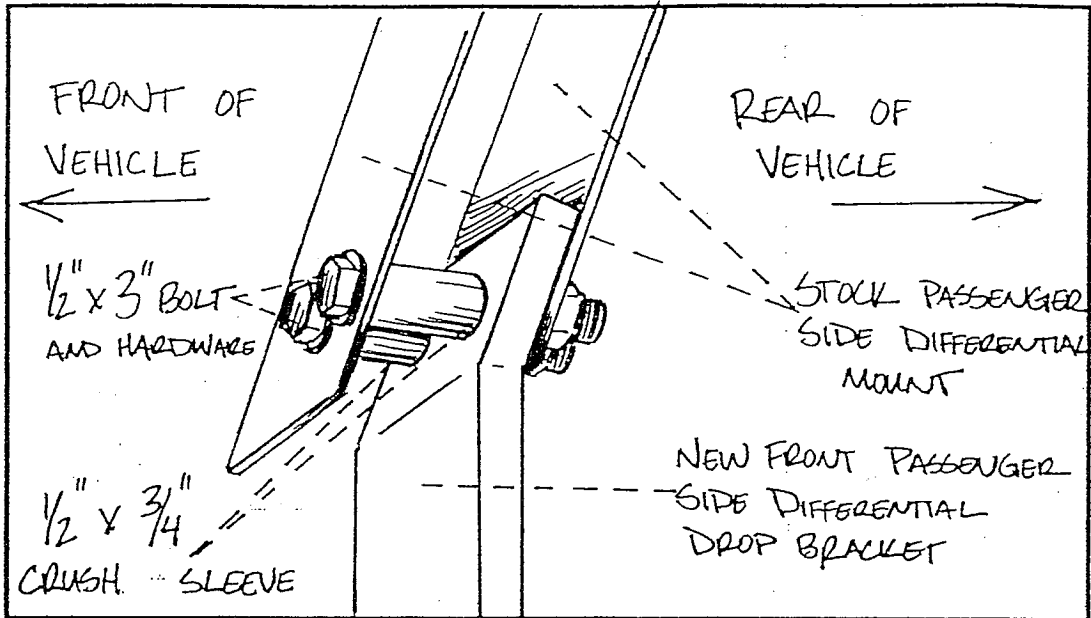

ILLUSTRATION # 9

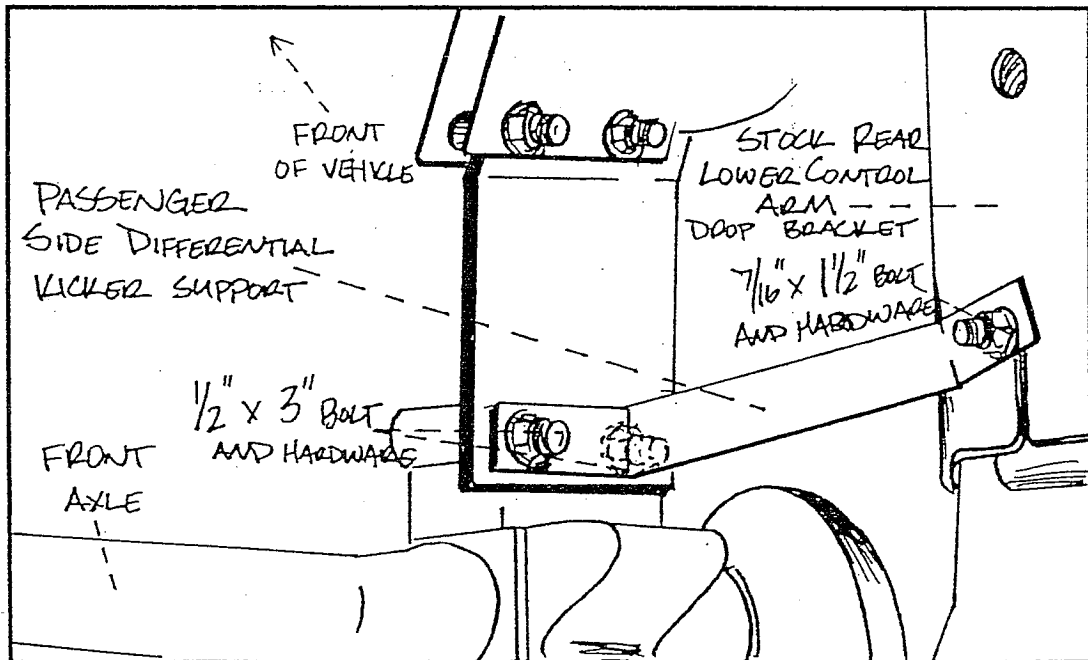

ILLUSTRATION # 10

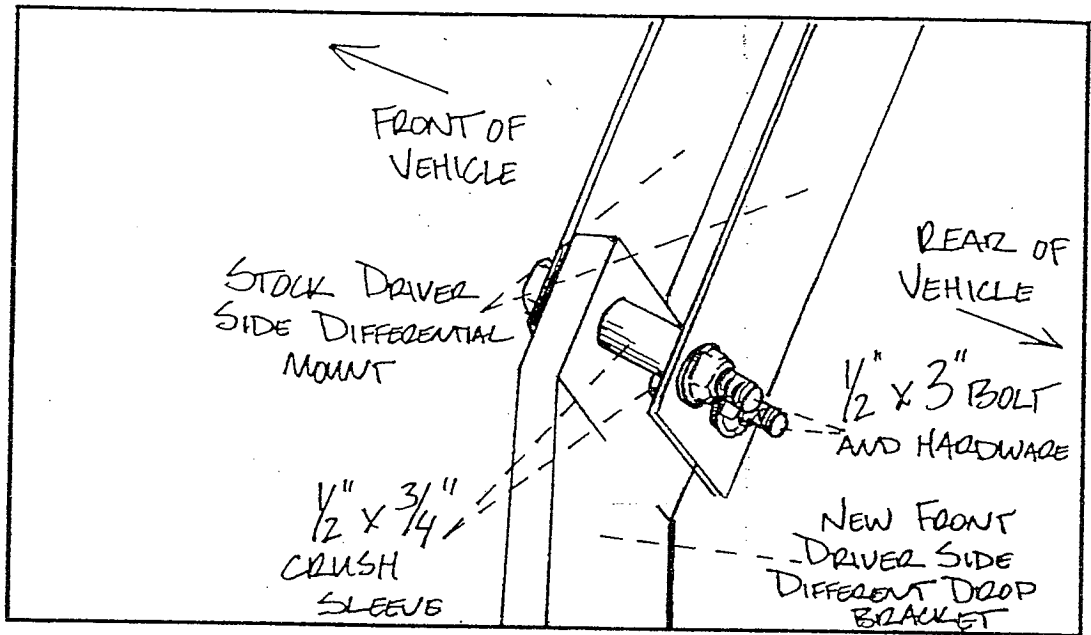

ILLUSTRATION # 11

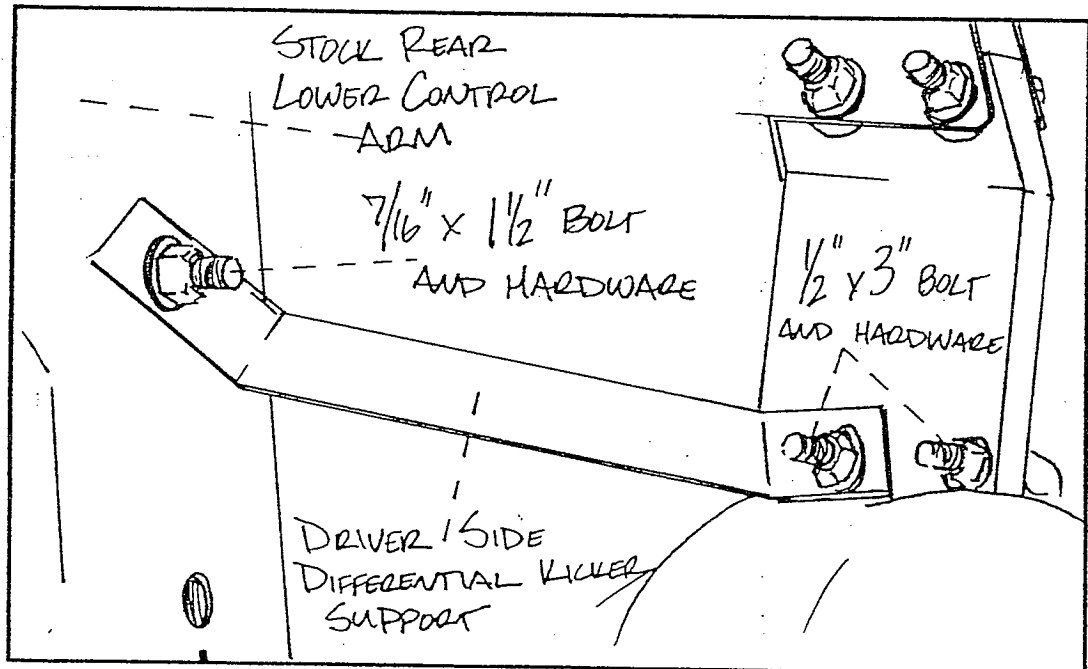

ILLUSTRATION # 12

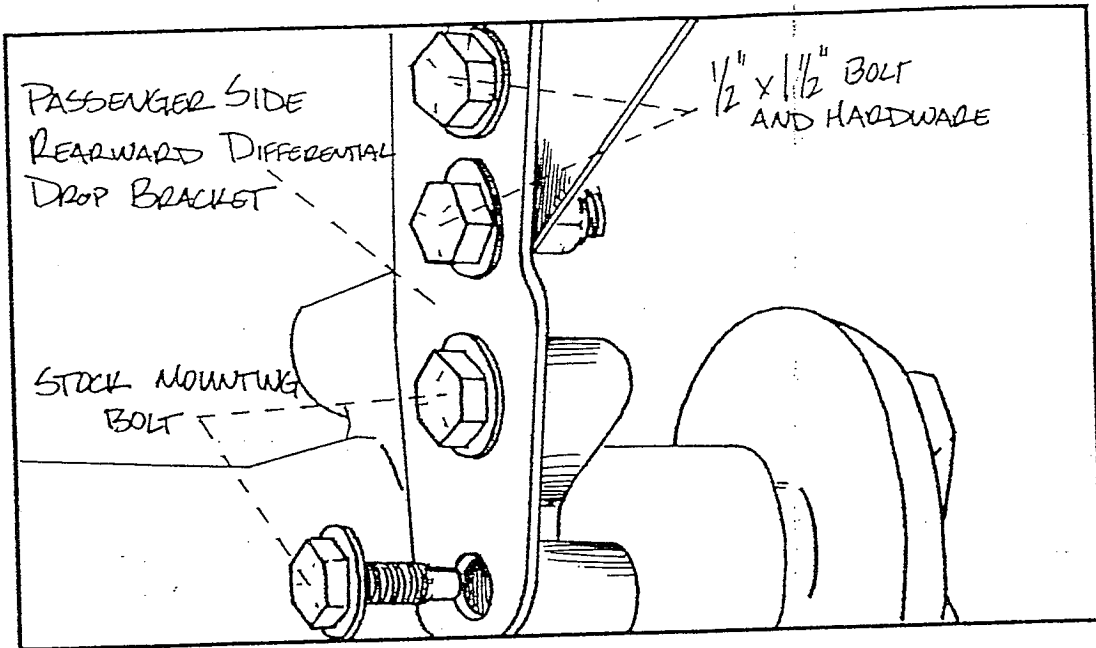

ILLUSTRATION # 13

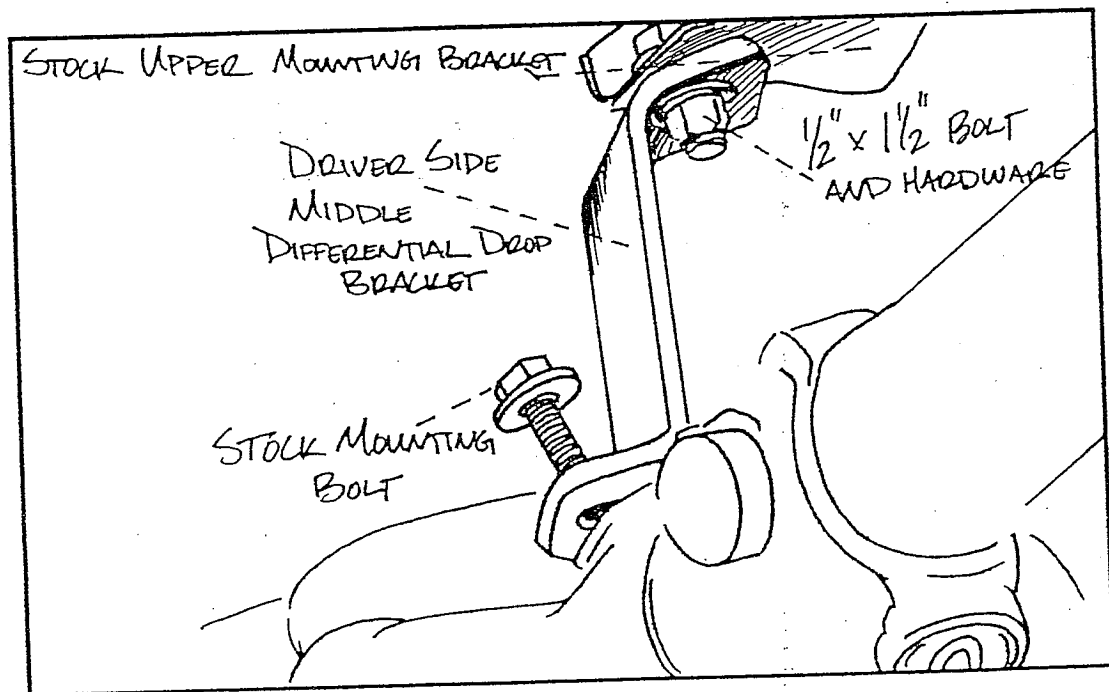

ILLUSTRATION # 14

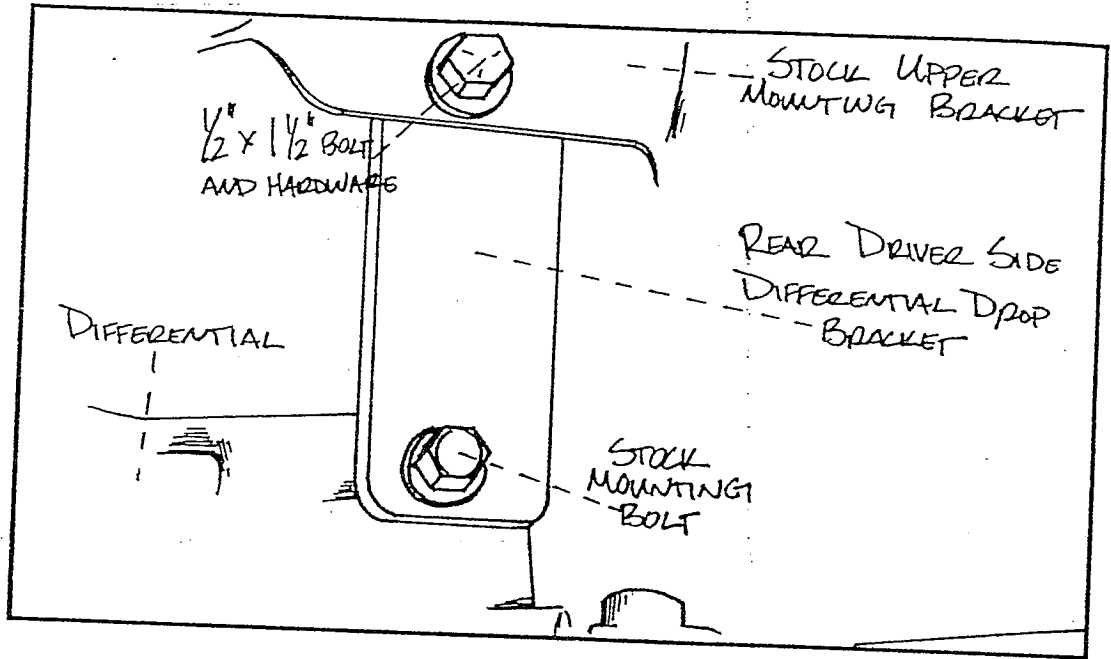

ILLUSTRATION # 15

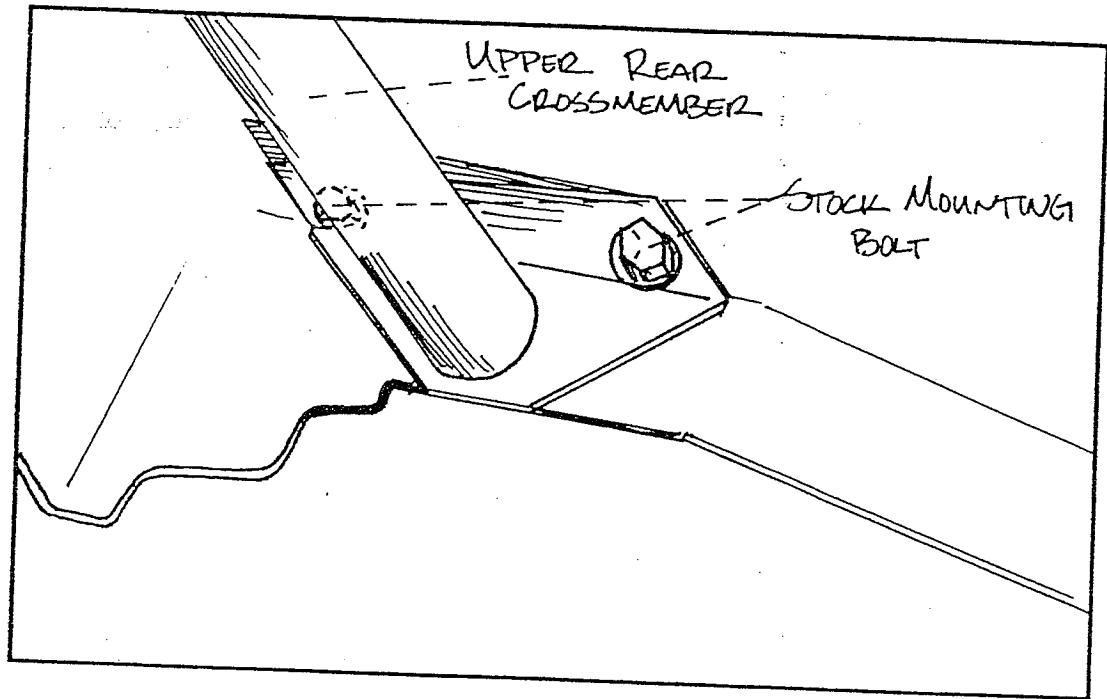

ILLUSTRATION # 16

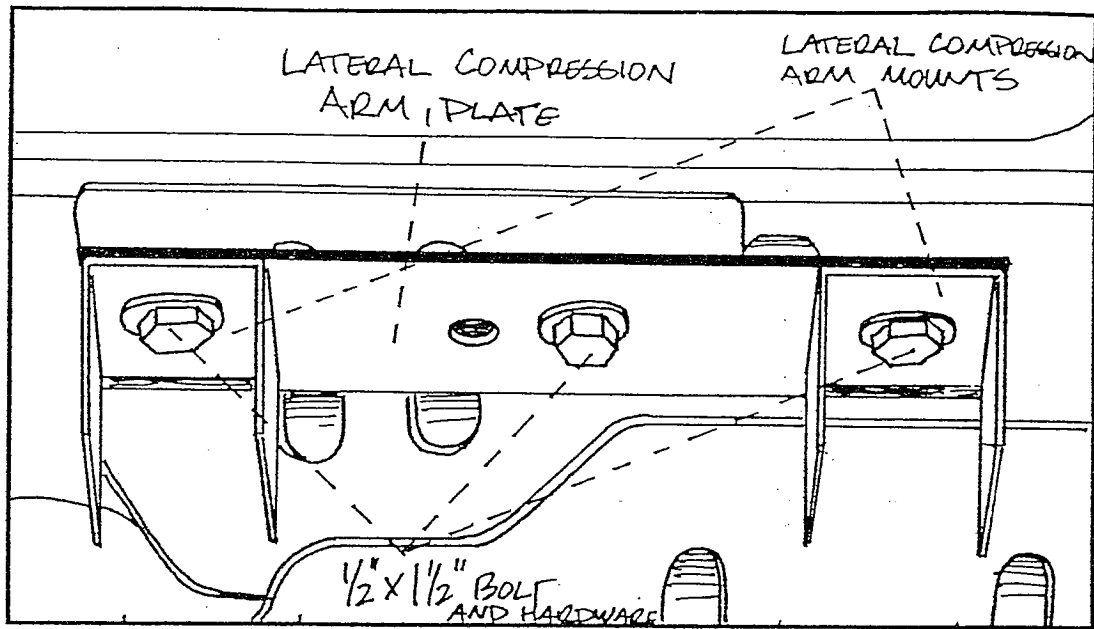

ILLUSTRATION # 17

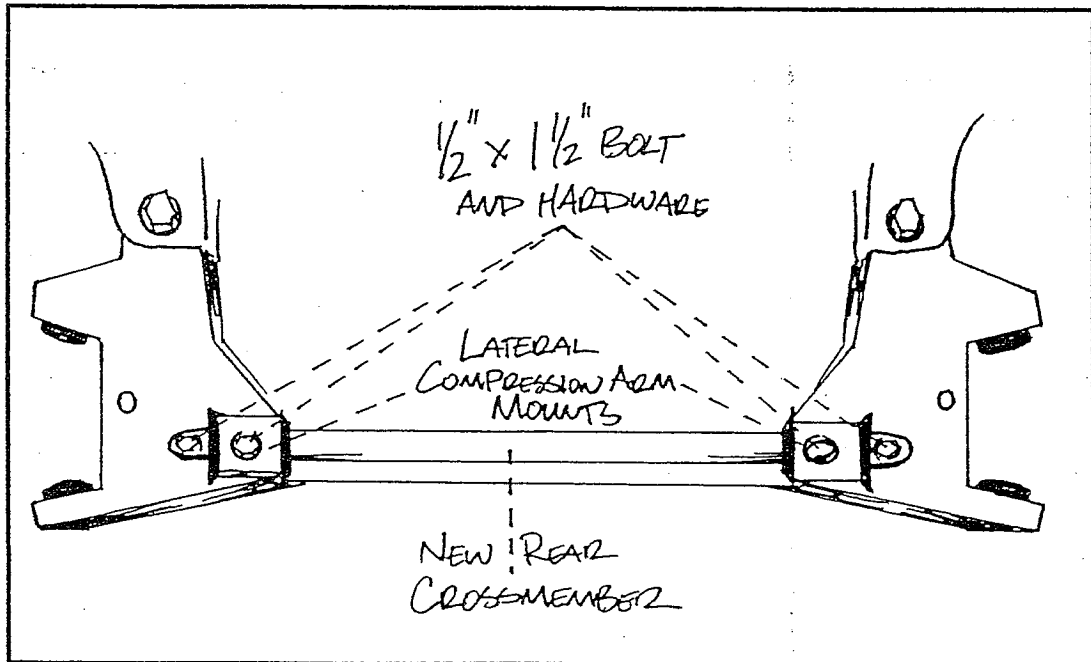

ILLUSTRATION # 18

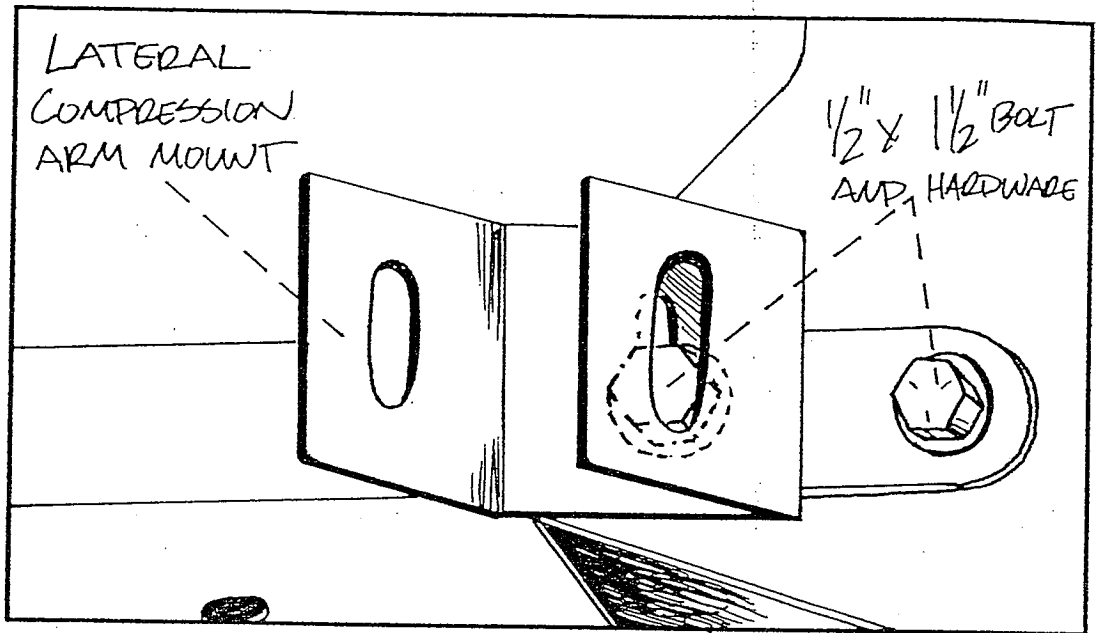
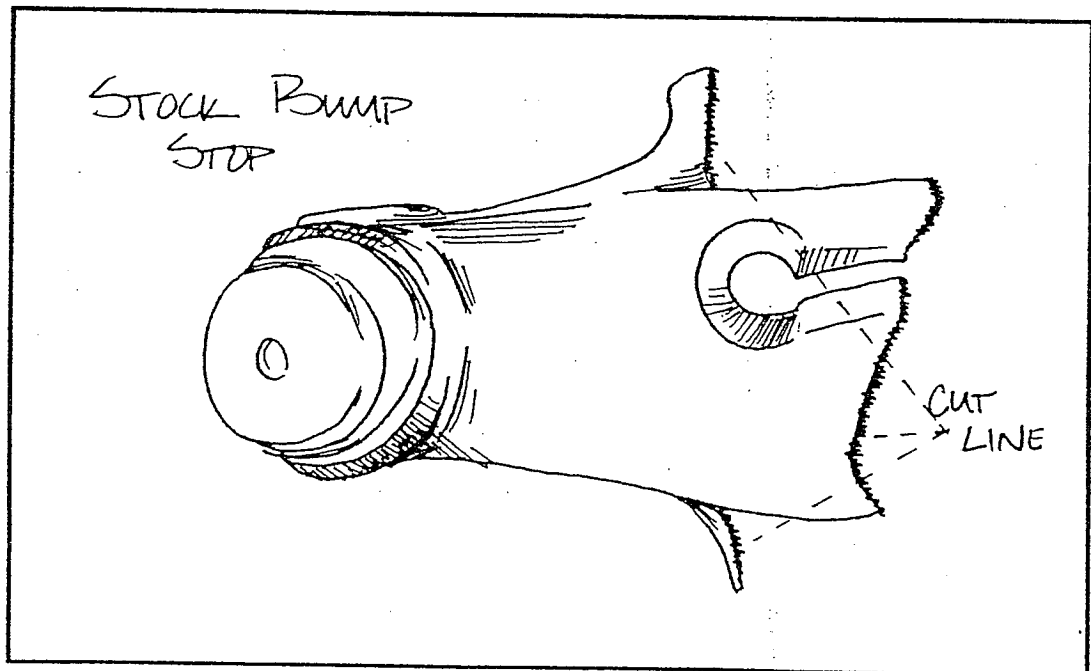

ILLUSTRATION # 19



ILLUSTRATION# 20

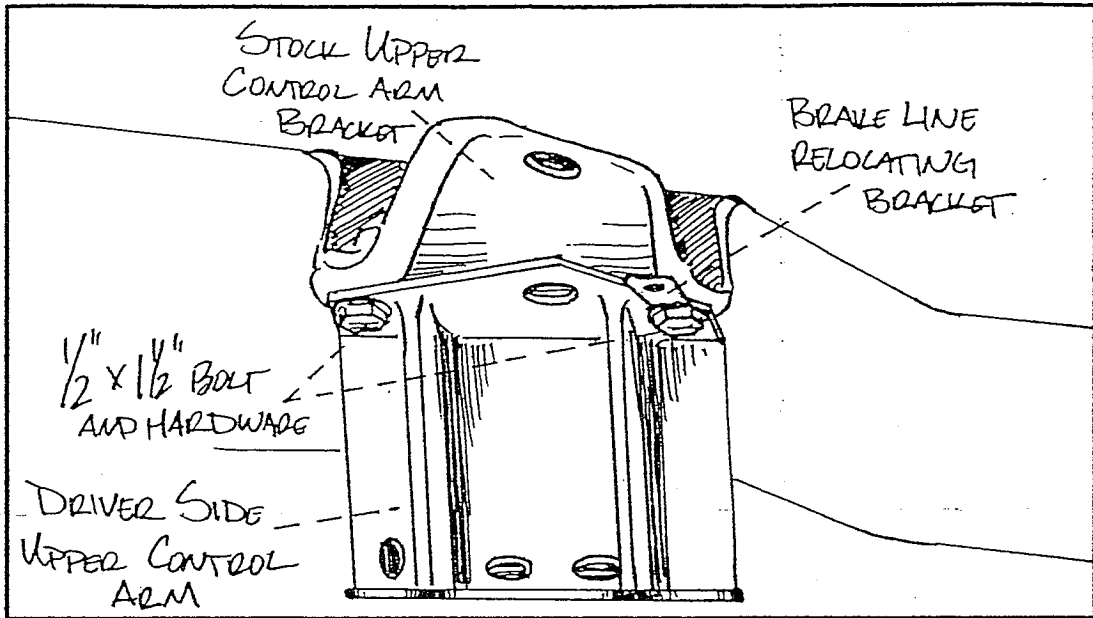

ILLUSTRATION # 21

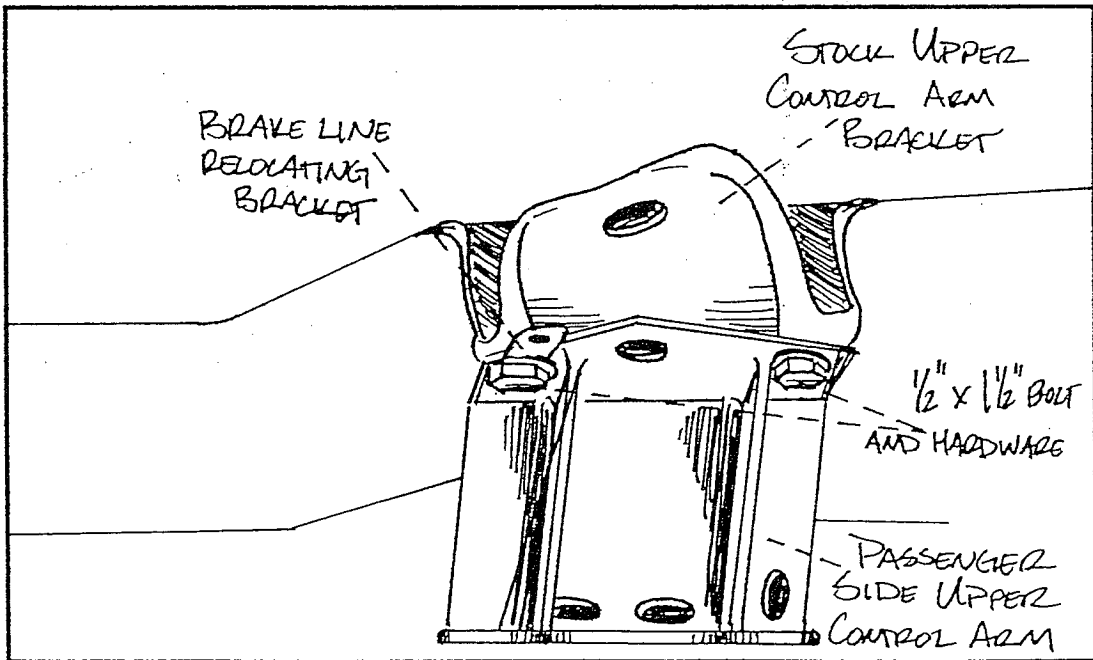

ILLUSTRATION # 22

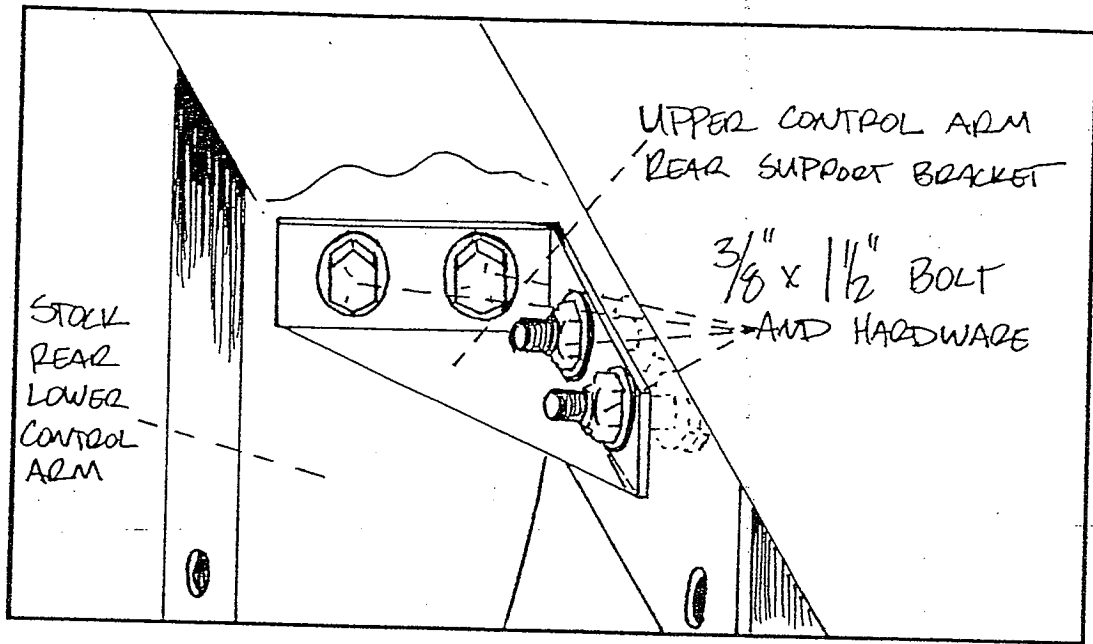

ILLUSTRATION # 23

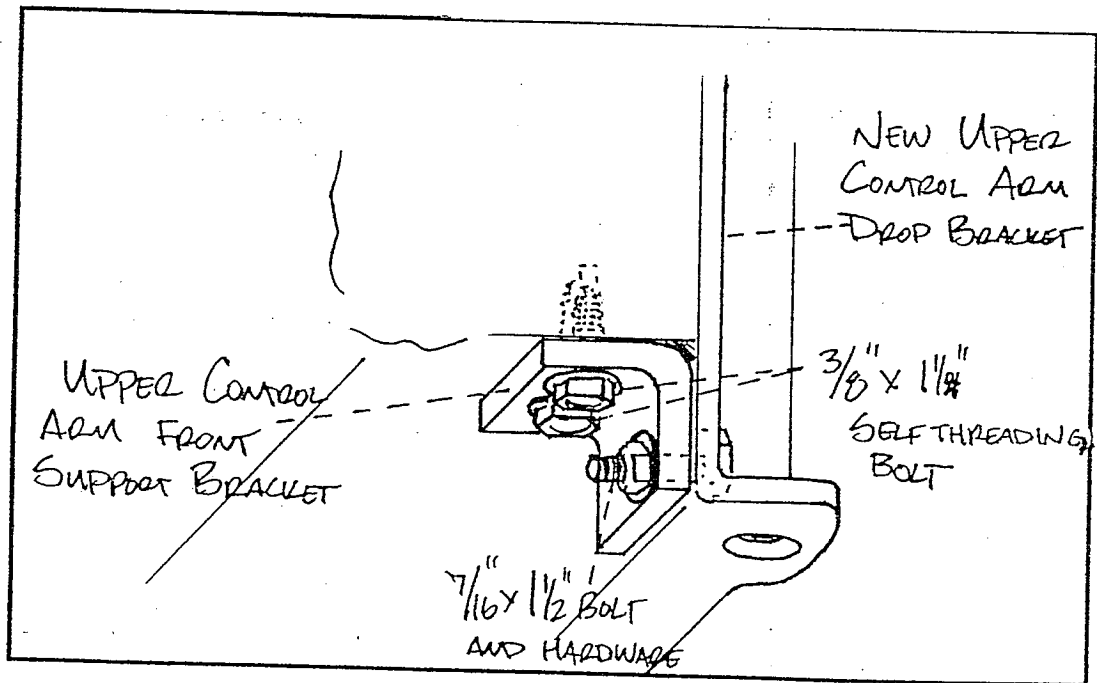

ILLUSTRATION # 24

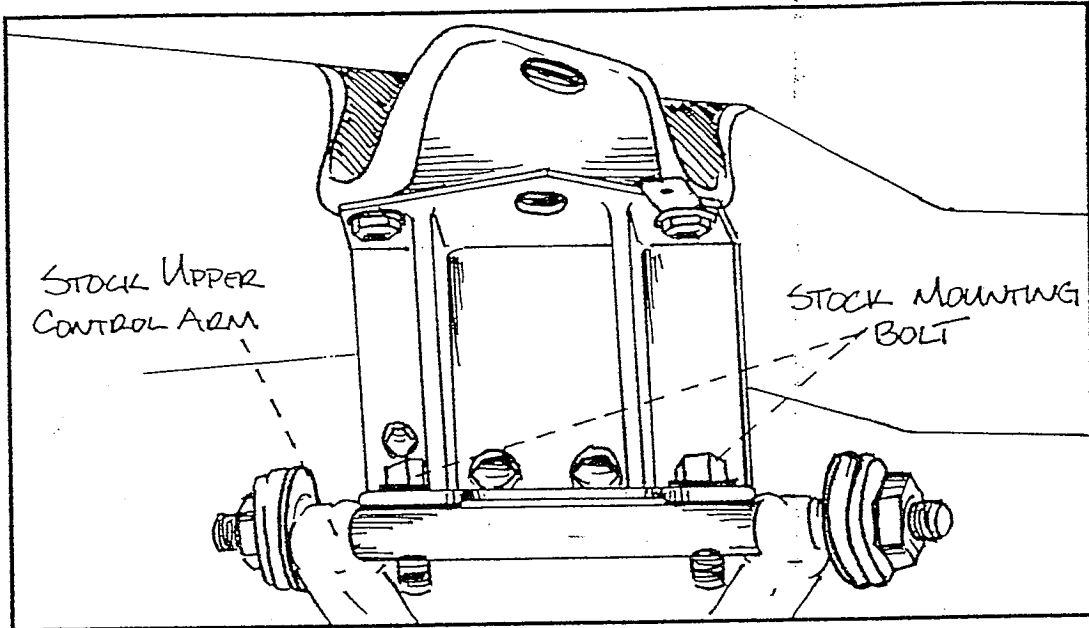

ILLUSTRATION # 25

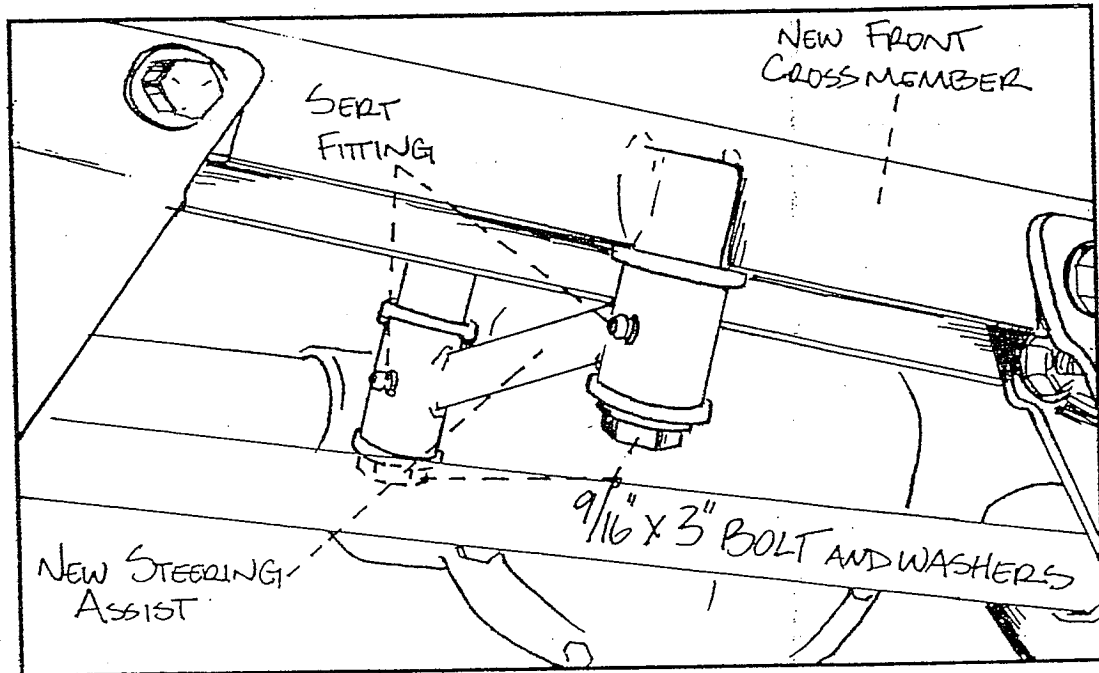

ILLUSTRATION # 26

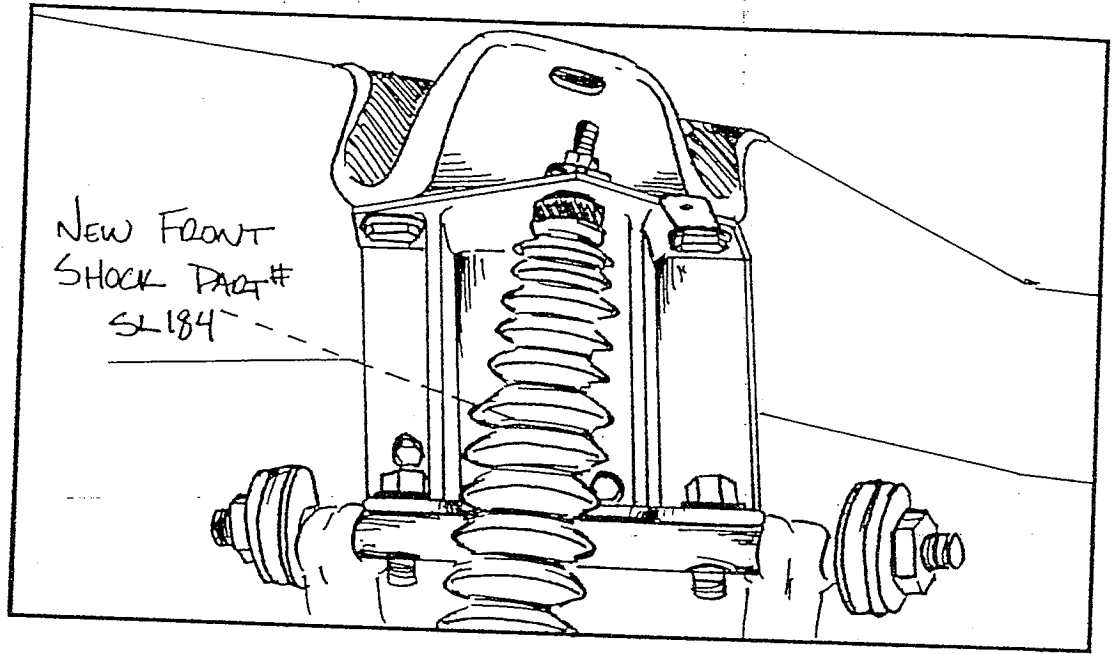

ILLUSTRATION # 27

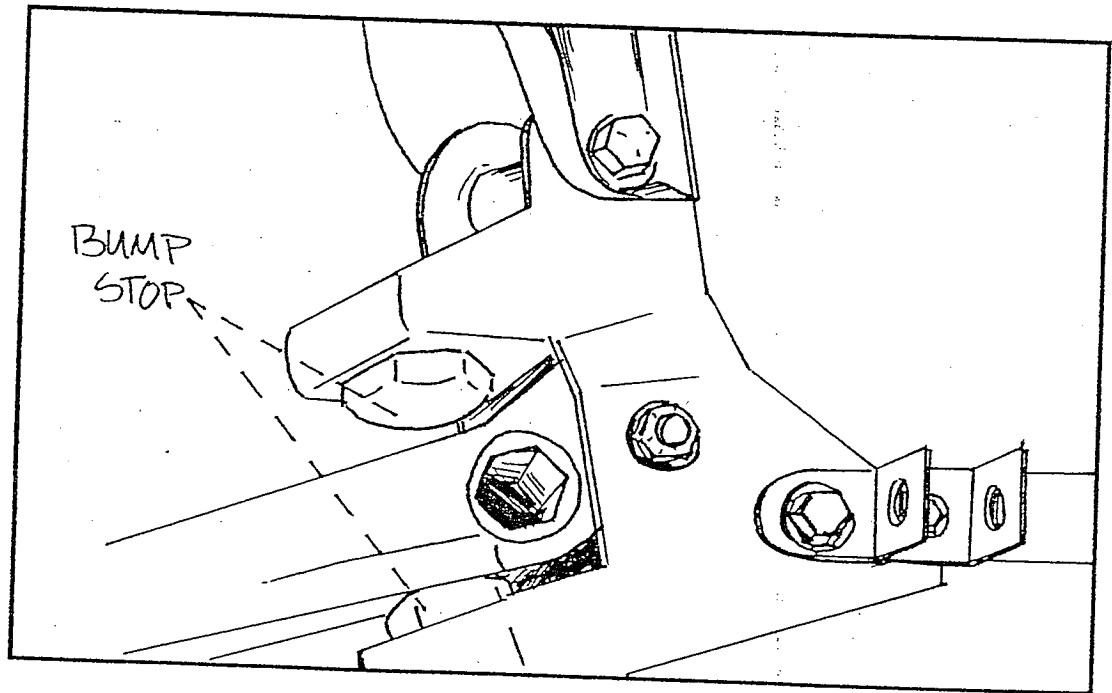

ILLUSTRATION # 28

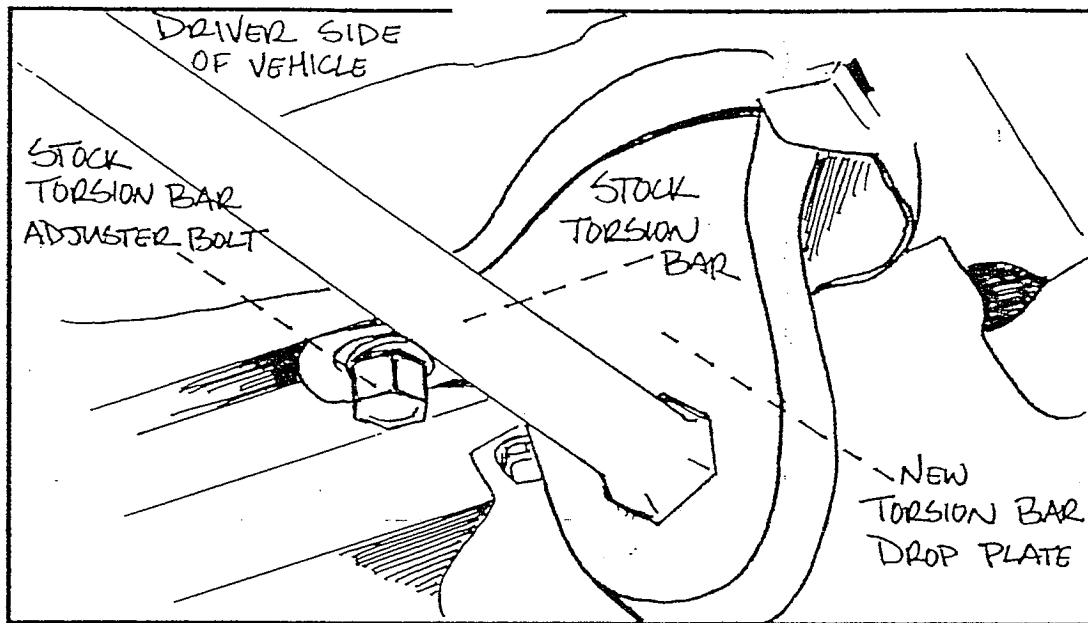

ILLUSTRATION # 29

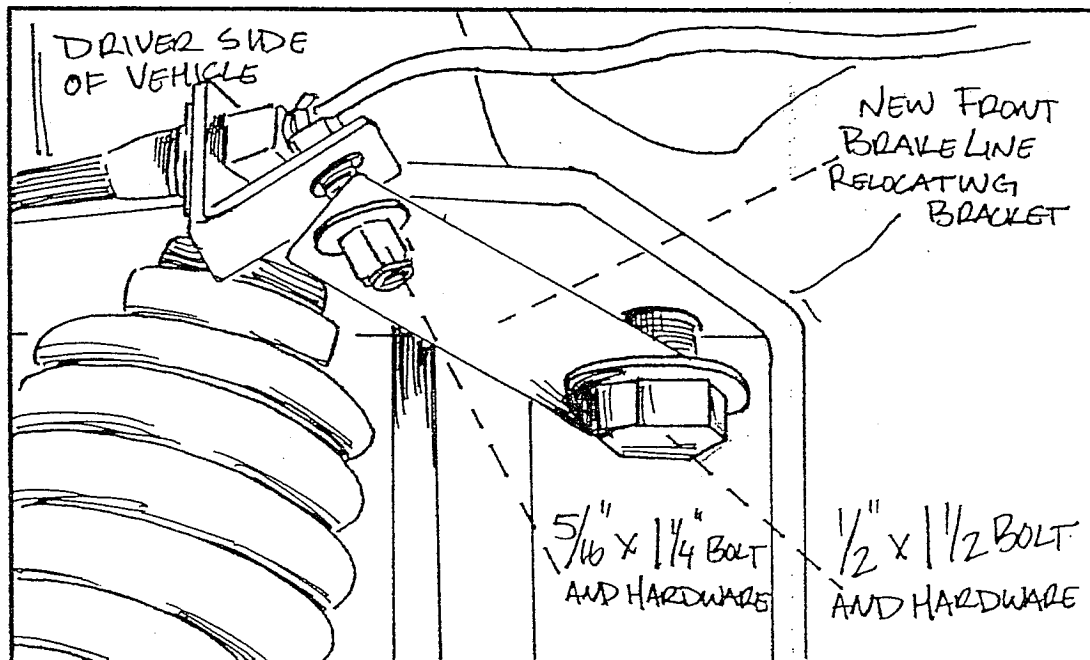

ILLUSTRATION # 30

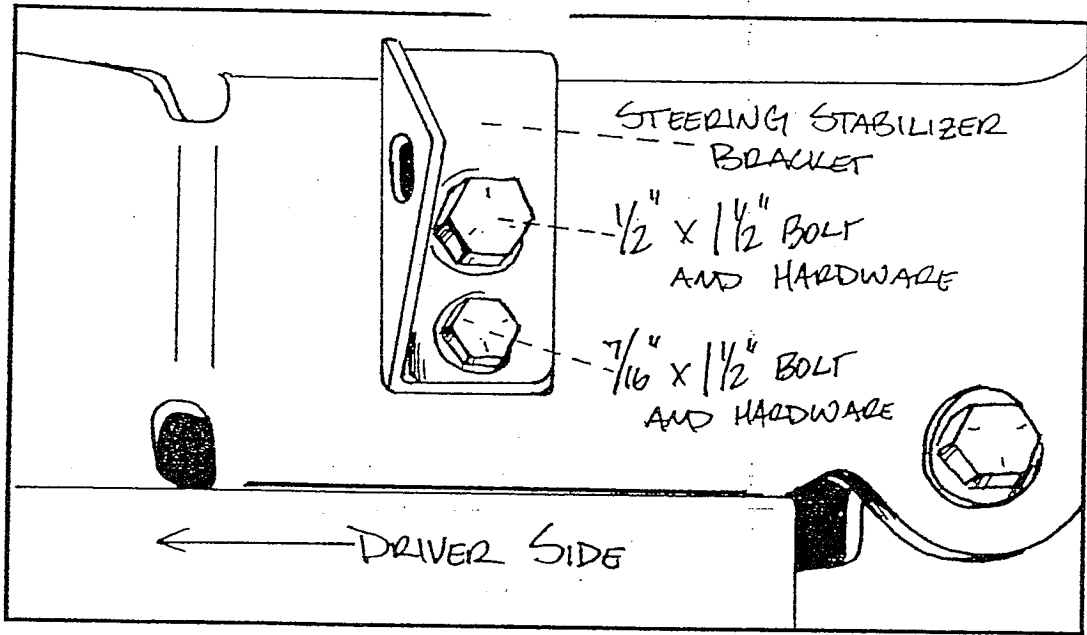

ILLUSTRATION # 31

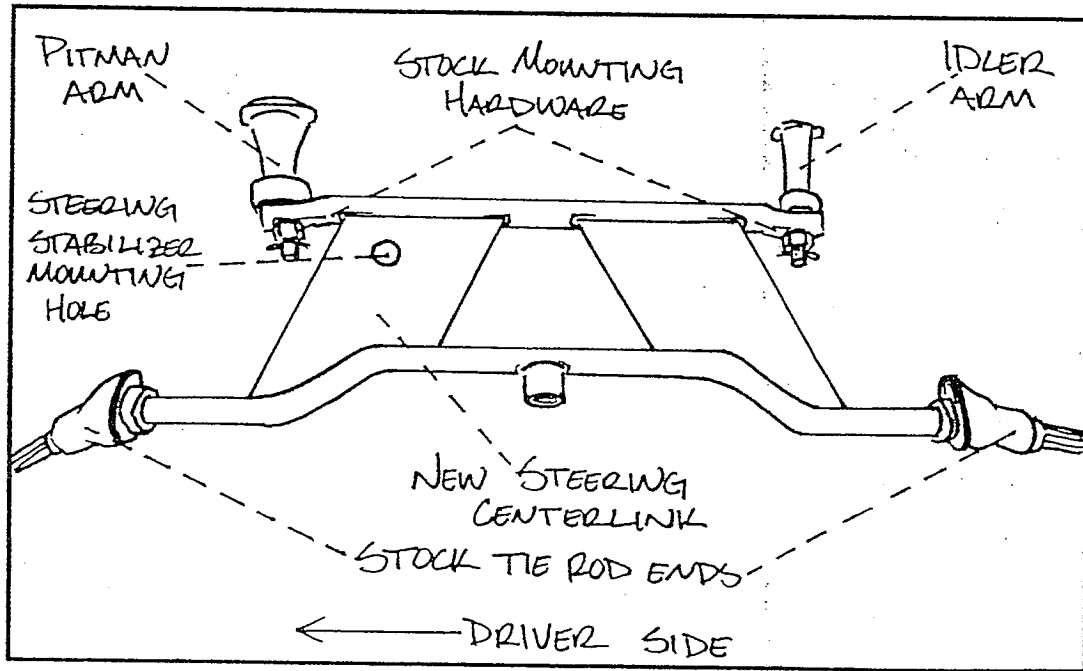

ILLUSTRATION # 32

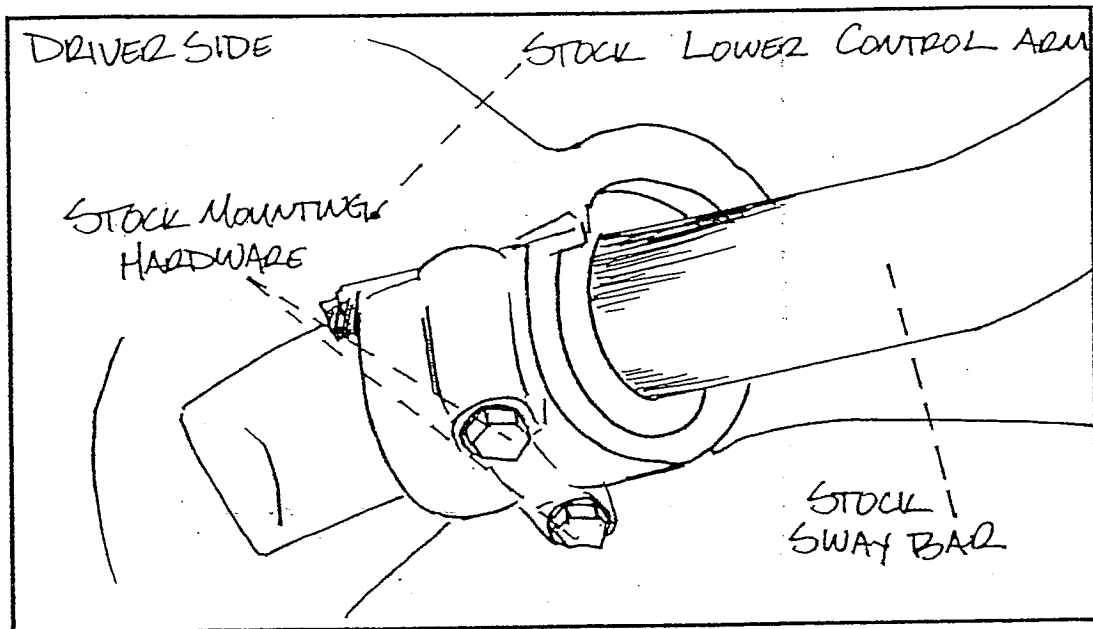
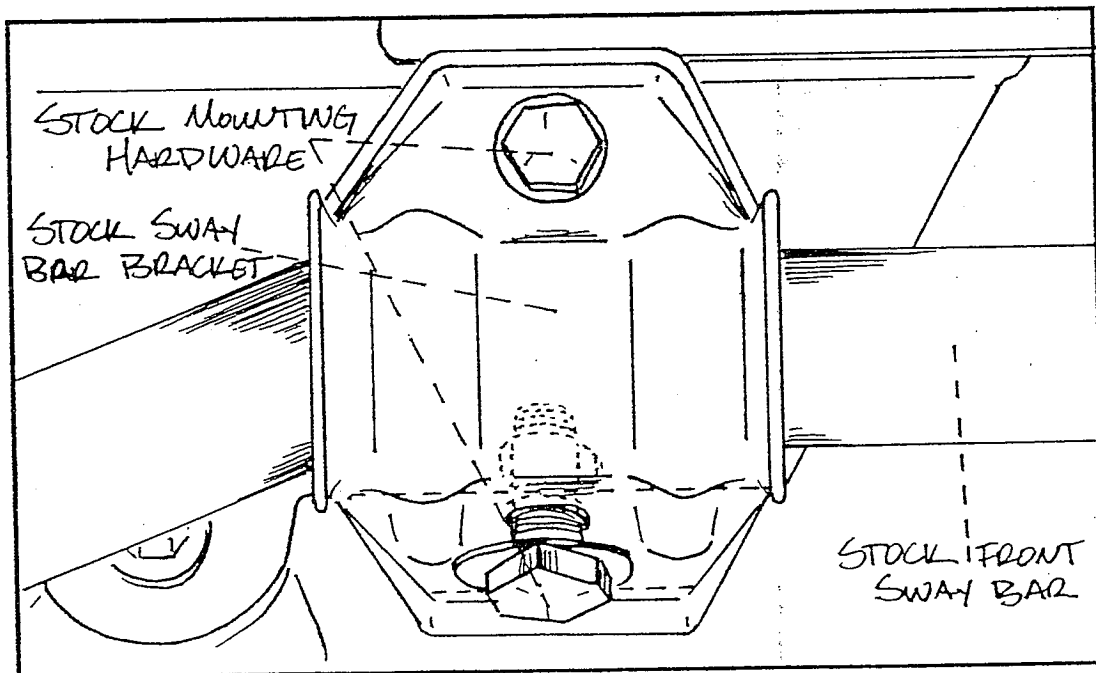

ILLUSTRATION # 33



ILLUSTRATION# 34

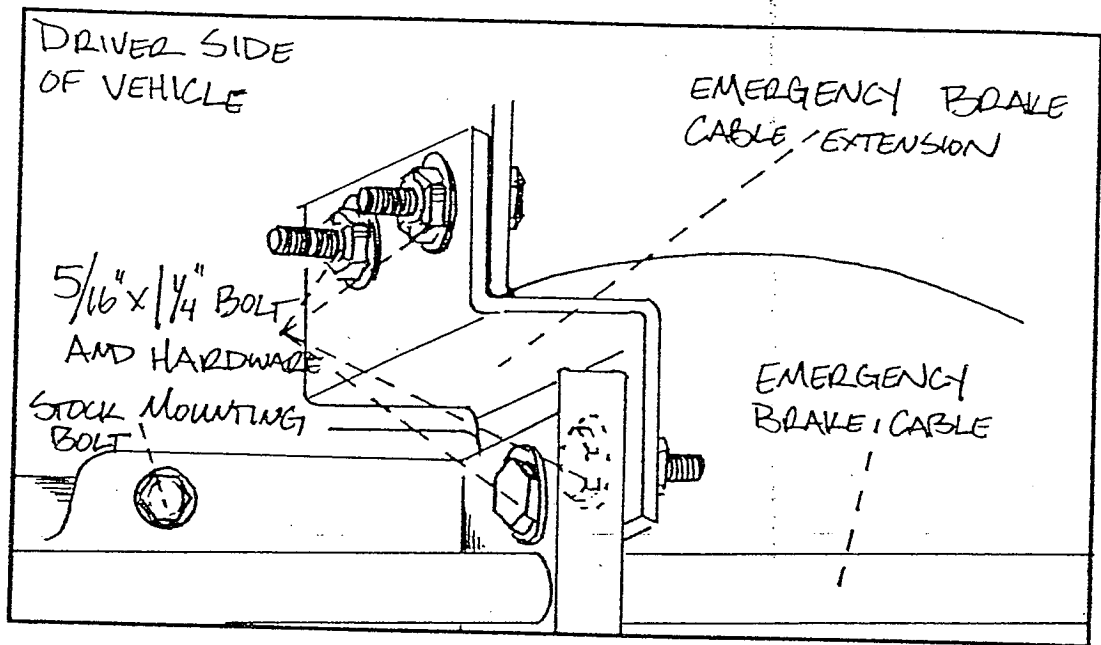

ILLUSTRATION # 35

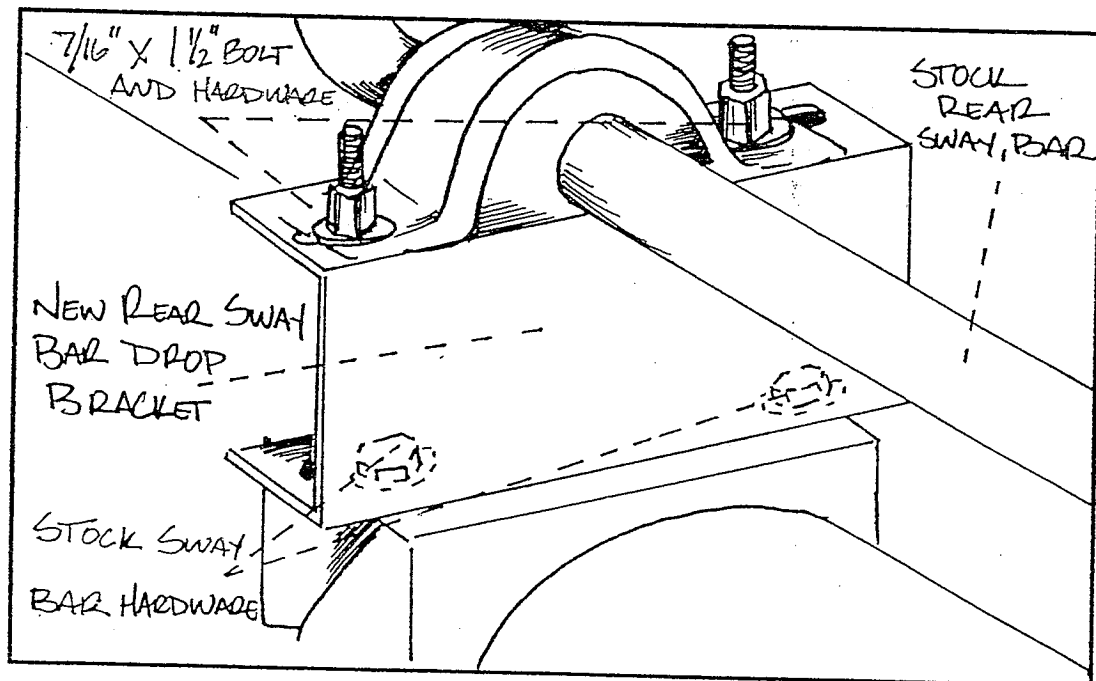

ILLUSTRATION # 36

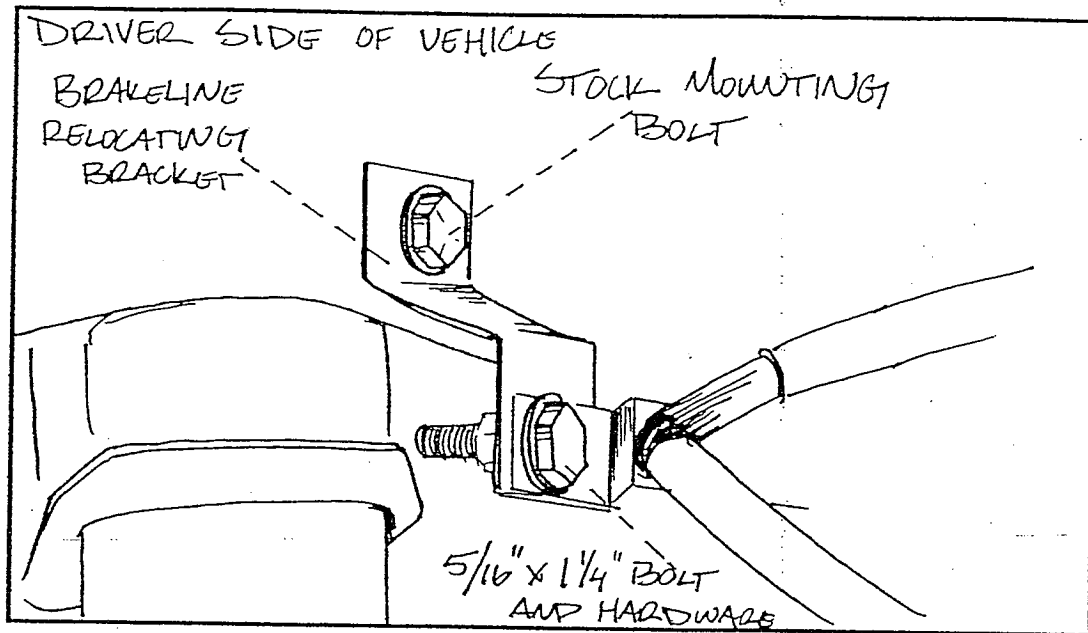

ILLUSTRATION # 37

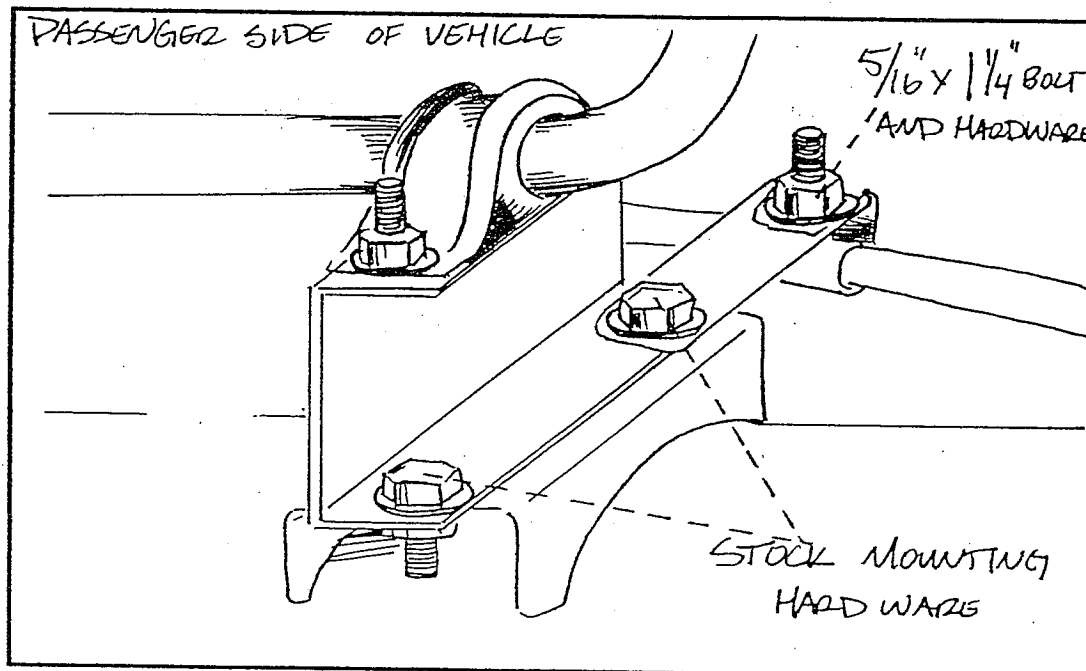

ILLUSTRATION # 38

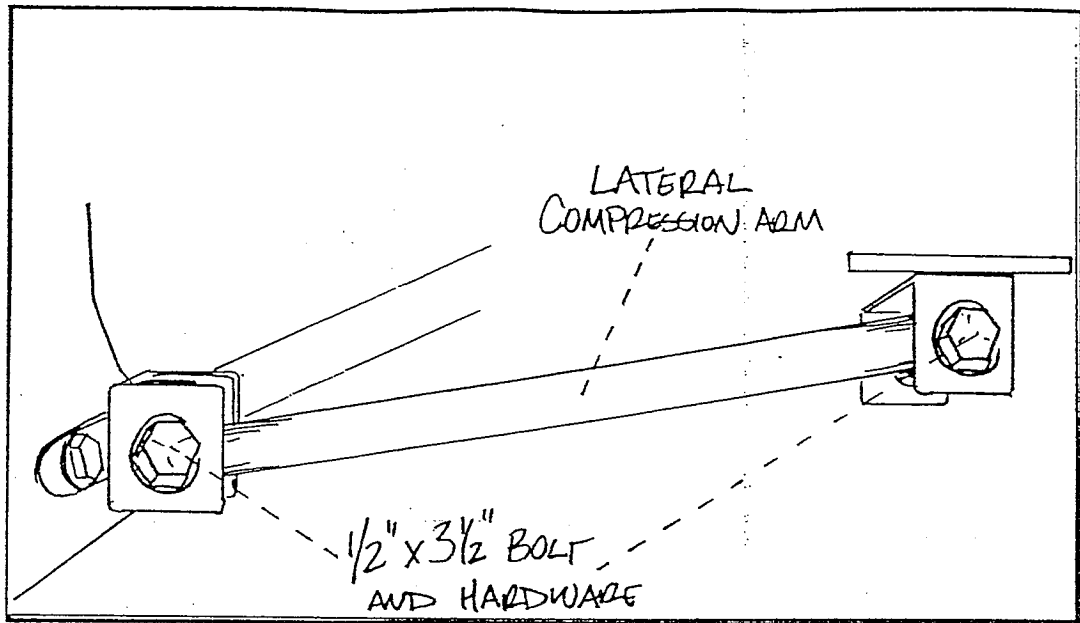
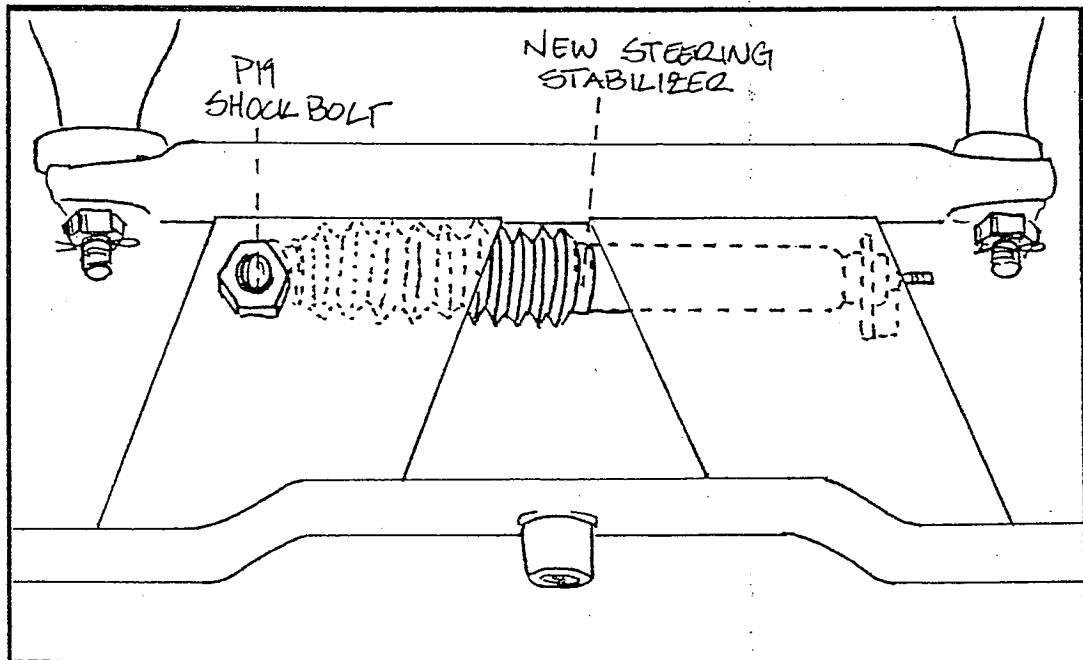

ILLUSTRATION # 39



ILLUSTRATION# 40

Dodge Durango / Dakota Parts Description



Photo # 1

(Top) Lower Rear Cross Member (Middle) Front Cross Member
(Bottom) Upper Rear Cross Member

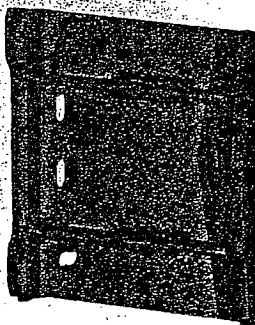
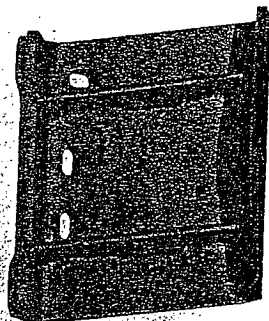

Photo # 2

(Left) Upper Control Arm Drop Bracket - Driver Side
(Right) Upper Control Arm Drop Bracket - Passenger Side

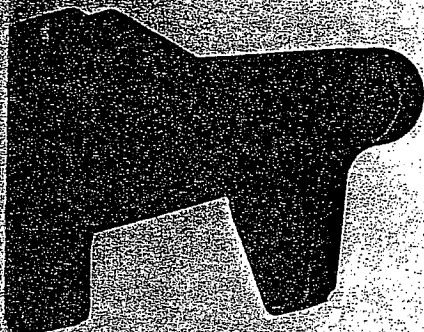

Photo # 3

Lower Control Arm Drop Bracket (Rear) - Qty. 2

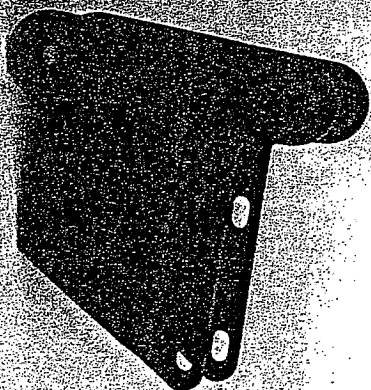

Photo # 4

Lower Control Arm Drop Brackets (Front) - Qty. 2

Dodge Durango / Dakota Parts Description Continue

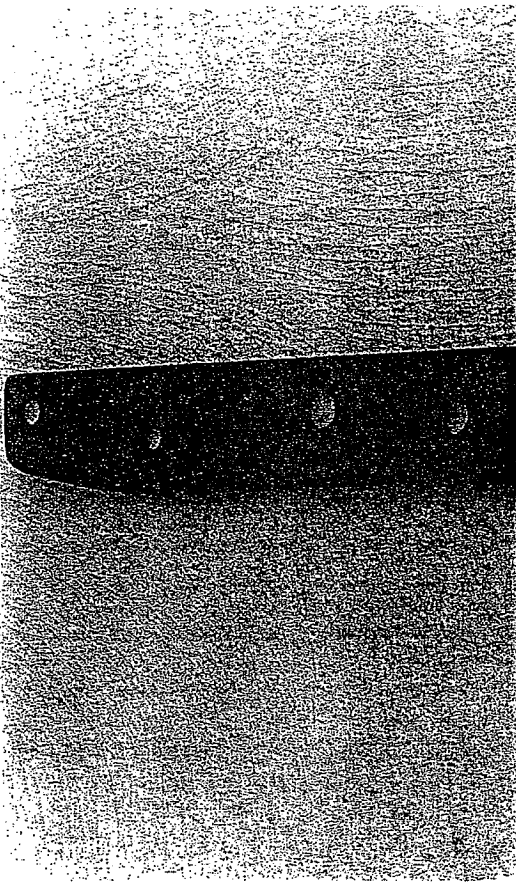

Photo # 6
Differential Drop Bracket - Passenger Side (Rear)

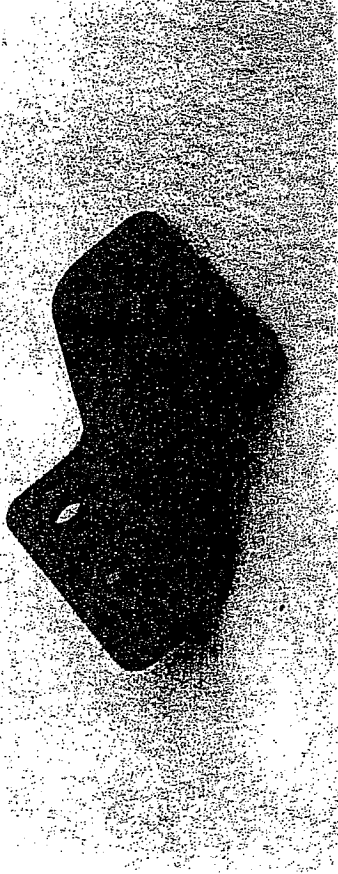

Photo # 5
Emergency Brake Cable Relocating Bracket (Durango Only)



Photo # 8
Differential Drop Bracket - Driver Side (Rear)

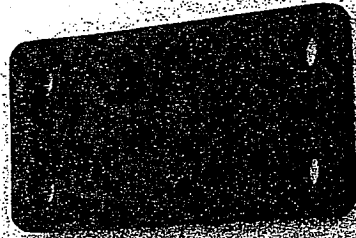
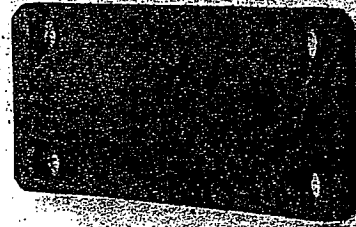

Photo # 7
(Left) Differential Drop Bracket - Passenger Side (Front) 1 3/4" center to center of holes
(Right) Differential Drop Bracket - Driver Side (Front) 2" center to center of holes



Dodge Durango / Dakota Parts Description Continue

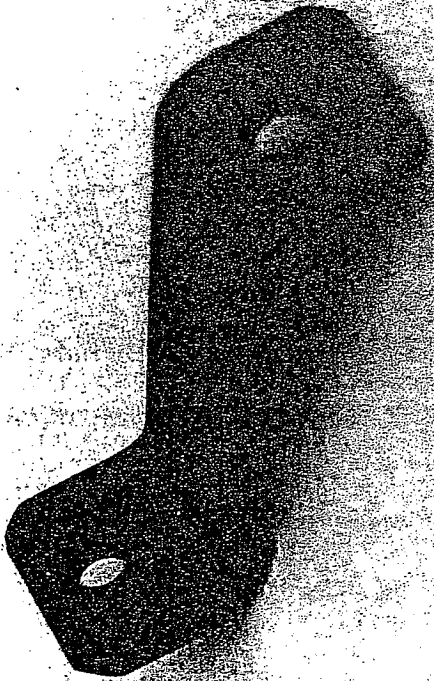

Photo # 9

Differential Drop bracket - Driver Side - Middle (Rear)

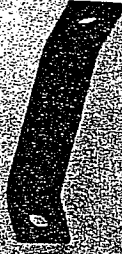
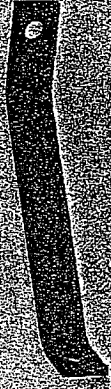

Photo # 10

(Left) Differential Kicker Support Bracket - Driver Side - Longer
(Right) Differential Kicker Support Bracket - Passenger Side - Short

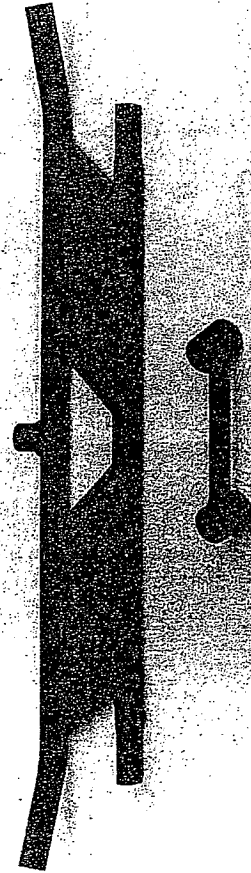

Photo # 11

(Top) Steering Center Link
(Bottom) Steering Assist

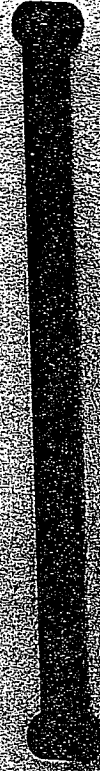

Photo # 12

(Top) Lateral Compression Arm Mount Plate (Middle) Lateral Compression Arms Qty. 2 (Bottom) Lateral Compression Arm Mounts Qty. 4

Dodge Durango / Dakota Parts Description Continue

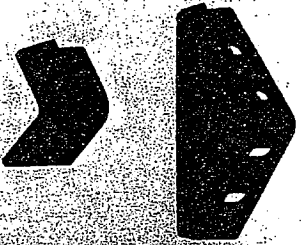

Photo # 13

(Top) Rear Upper Control Support Bracket - Qty. 2
(Bottom) Front Upper Control Arm Support Bracket - Qty. 2

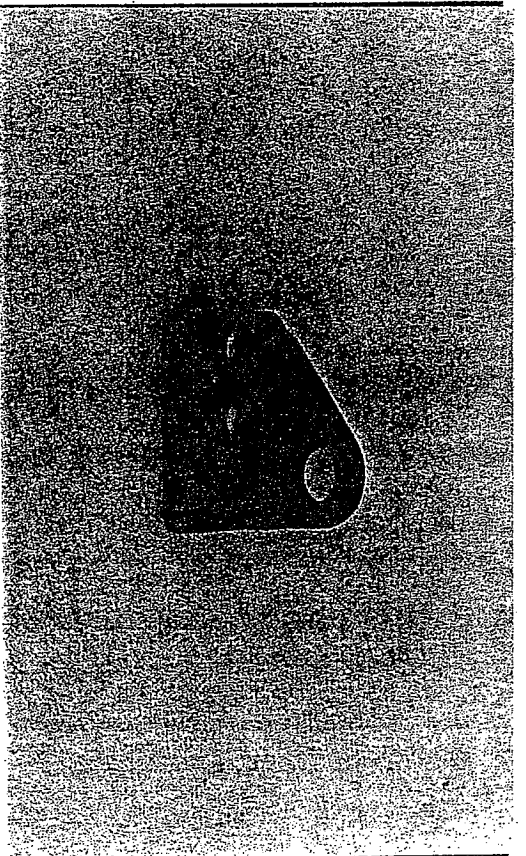

Photo # 14

Steering Stabilizer Bracket

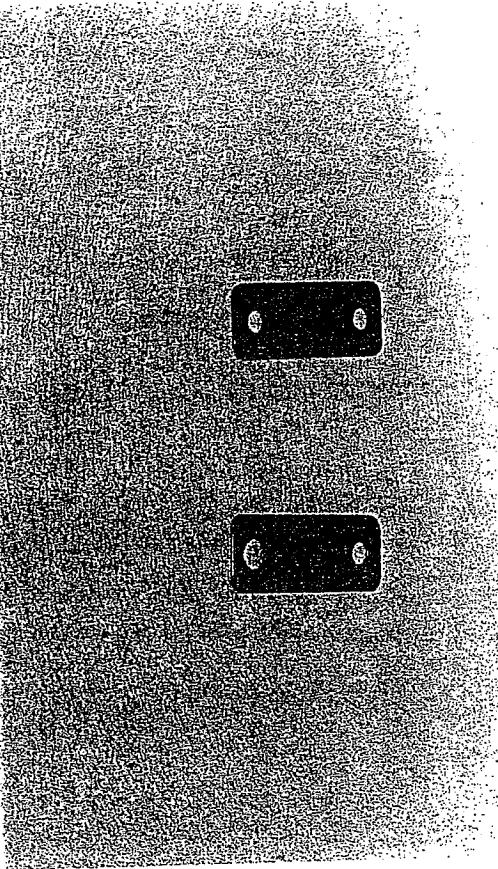

Photo # 15

Brakeline Extensions (3) 1/2" Hole x 5/16" Hole
Brakeline Extension (1) 5/16" x 5/16" Hole

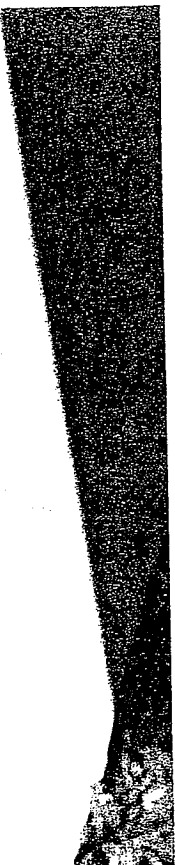
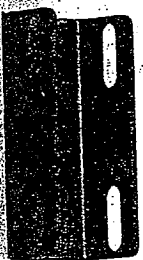

Photo # 16

Rear Sway Bar Extensions - Durango Only



Dodge Durango / Dakota Parts Description Continue

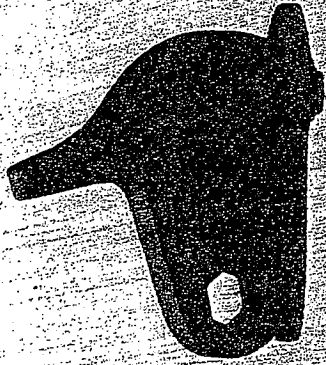

Photo # 17

Torsion Bar Drop Blocks - Qty. 2

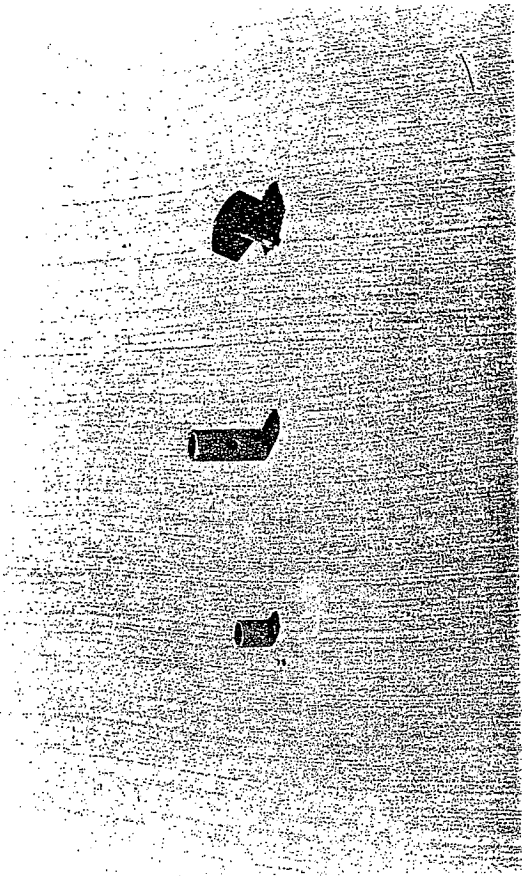

Photo # 18

(Left) Differential Spacer Sleeves - Qty. 4 (Middle) 916218SLWH Qty. 2
916218SLWOH Qty. 4 (Right) Bump Stops - Qty. 4